

# SANUS | SYSTEMS

THE UNION OF FORM AND FUNCTION

## Assembly Instructions for Model: EFAS-II

Thank you for choosing the Sanus Systems Model EFAS-II. Every effort has been made to ensure that your Sanus Systems furniture is perfect. If you have questions or feel that there is a problem of any kind, please contact us at 800-359-5520 or at [www.sanus.com](http://www.sanus.com). We can quickly help with any issues regarding assembly or missing parts. Replacement parts for Sanus systems products purchased through authorized dealers will be shipped directly to you.

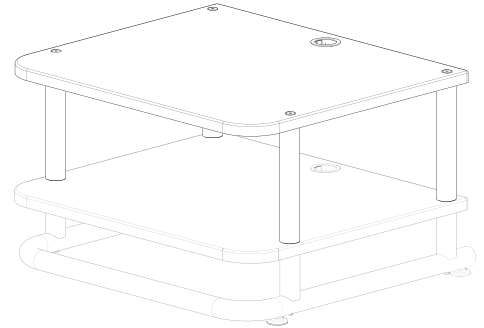

**Supplied Parts List:** (All threaded fasteners are shown full size.)



**8" Pillar - A**  
Qty. 4

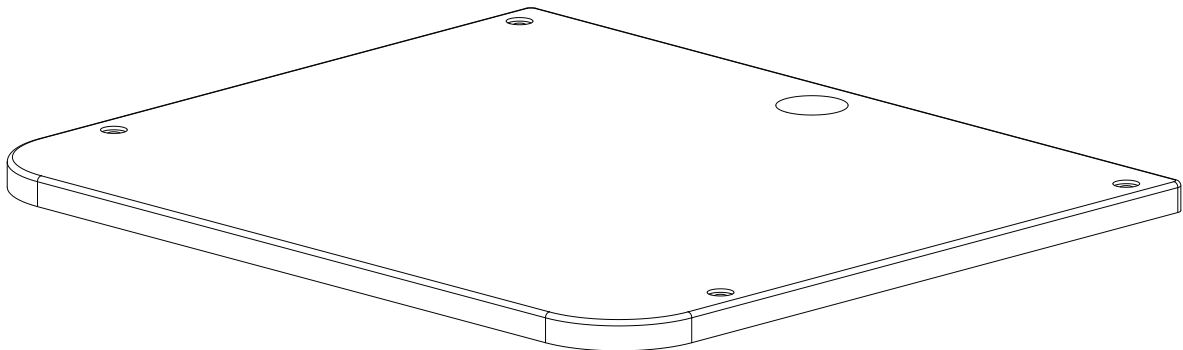

**Audio Shelf - B**  
Qty. 1

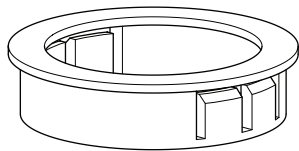

**Wire Bushing - C**  
Qty. 1

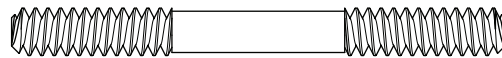

**Shelf Connector - D**  
Qty. 4

**NOTE: Step 1 is necessary only if the EFAB-II assembly has been previously completed.**

**Step 1 - Remove existing Top Bolts**

Remove the four Top Bolts securing the Audio Shelf.

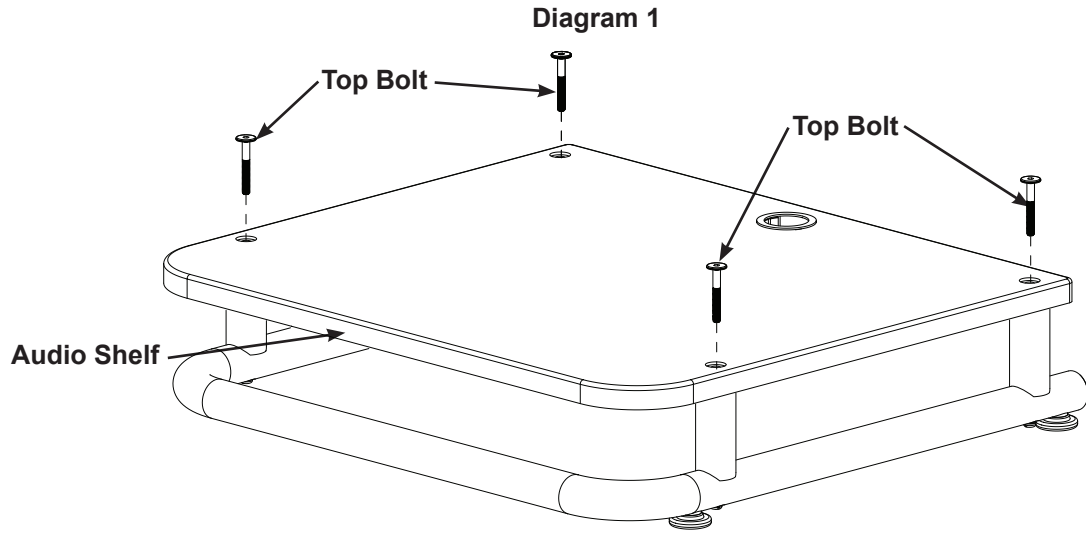

---

**Step 2 - Install Shelf Connectors, and 8" Pillars**

Thread a Shelf Connector (**D**) securely into the four 3" Cope Tubes.

Screw the 8" Pillars (**A**) onto the Shelf Connectors (**D**).

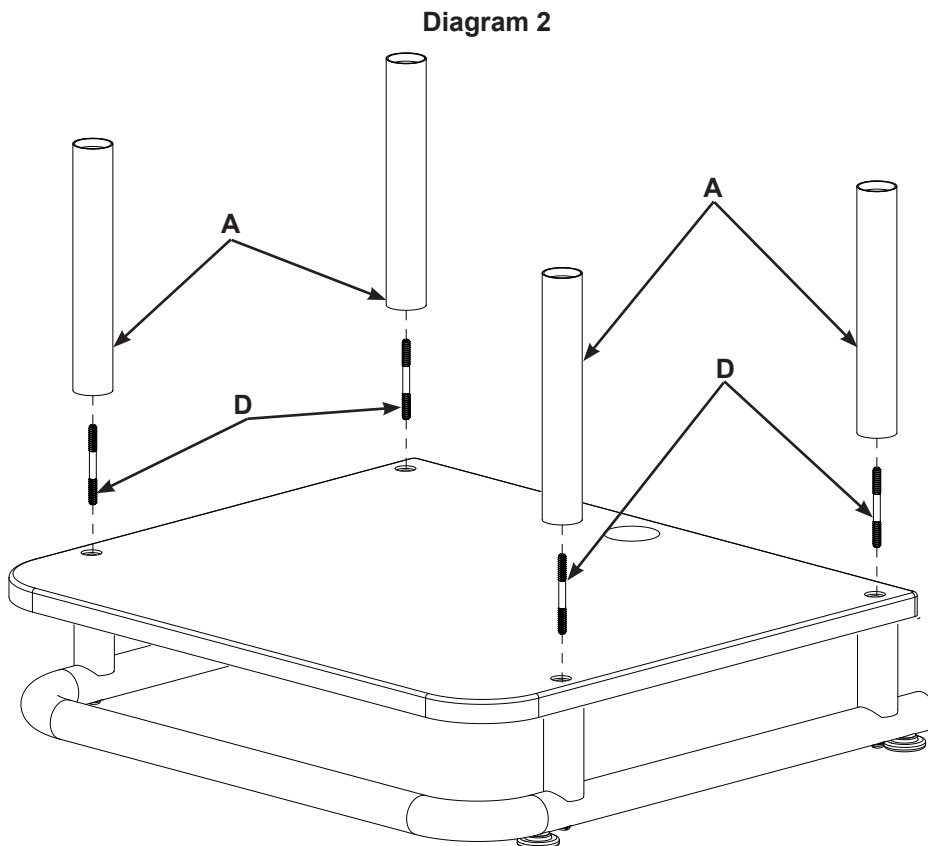

### Step 3 - Secure new Audio Shelf to 8" Pillars

Place the new Audio Shelf (B) on the 8" Pillars (A); then, using an Allen Key and the four Top Bolts removed from the EFAB-II, secure the new Audio Shelf to the 8" Pillars.

Press the Wire Bushing (C) into the hole in the Audio Shelf (B).

Diagram 3

