

SANUS SYSTEMS

THE UNION OF FORM AND FUNCTION

Assembly Instructions for Model: WFAV44

Thank you for choosing Sanus Systems Woodbrook Furniture. The Woodbrook Furniture is constructed of real hardwood and resonance dampening MDF.

Safety Warning: If you do not understand these directions, or have any doubts about the safety of the installation, please call a qualified contractor or contact Sanus at 800.359.5520 or www.sanus.com. Check carefully to make sure that there are no missing or defective parts. Our customer service representatives can quickly assist you with installation questions and missing or damaged parts. Replacement parts for products purchased through authorized dealers will be shipped directly to you. Never use defective parts. Improper installation may cause damage or serious injury. Do not use this product for any purpose that is not explicitly specified by Sanus Systems. Sanus Systems can not be liable for damage or injury caused by incorrect assembly, or incorrect use. Please call Sanus Systems before returning products to the point of purchase.

Required Tools: Phillips screw driver

Supplied Parts and Hardware: Some parts may be pre-assembled together*

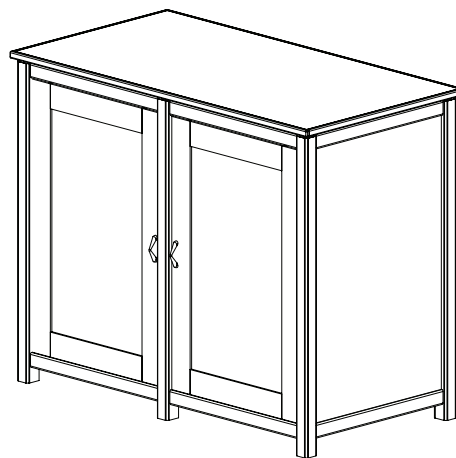

Hardware: Shown as actual size

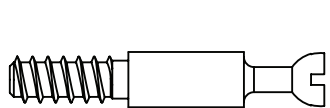

(16) Cam Pin - a

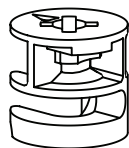

(16) Cam - b

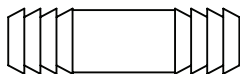

(6) Dowel Pin - c

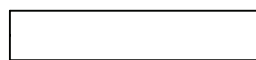

(16) Dowel - d



(32) Shelf Pin - e

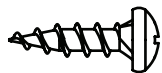

(8) Wood Screw - f

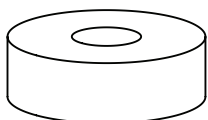

(6) Spacer - g

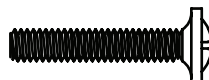

(4) Phillips Bolt - h

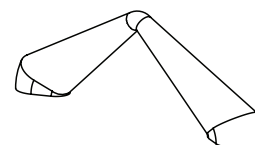

(2) Door Handle - i*



(8) Hinge Screw - j

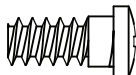

(8) Hinge Plate Screw - k

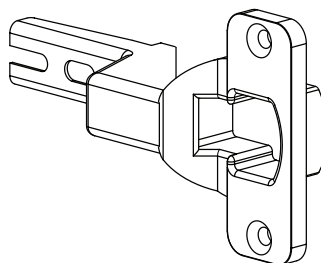

(4) Hinge - l*

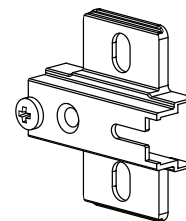

(4) Hinge Plate - m*

Parts: Not Shown as actual size

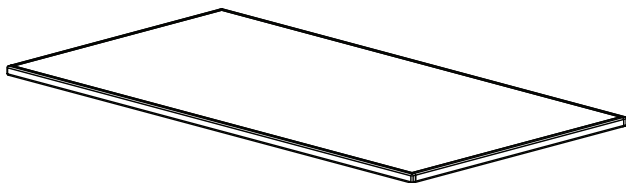

(1) Top - n



(4) Front Stretcher - o

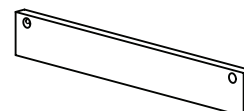

(4) Back Stretcher - p

Parts List (Cont)

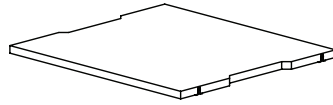

(2) Bottom Shelf - q

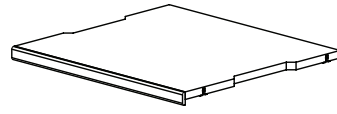

(6) Mid Shelf - r

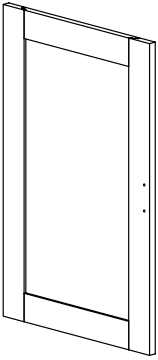

(2) Door - s

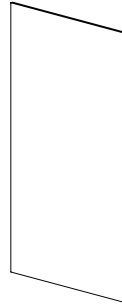

(2) Wood Panel Insert - t

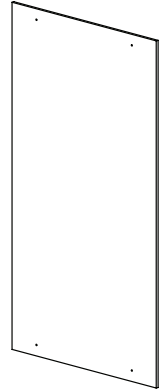

(2) Back Panel - u

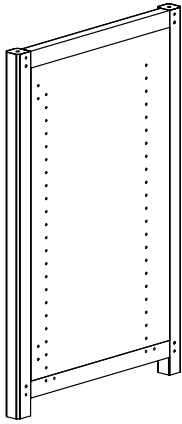

(1) Left Side Panel - v

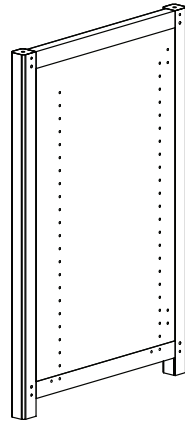

(1) Right Side Panel - w

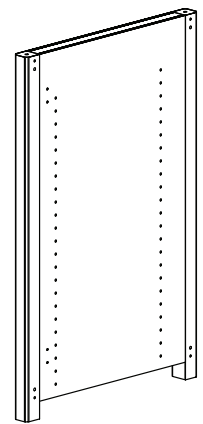

(1) Center Panel - x

Step 1: Prepare the Side Panels and Center Panel

Thread a Cam Pin (a) into each of the smaller holes in each Panel (v,w,x). Tighten each Cam Pin with a Phillips screw driver. Insert a Dowel (d) into the larger adjacent hole in the Panels. See Diagram 1 for assistance. Note: Center Panel not shown in Diagram 1.

Detailed View

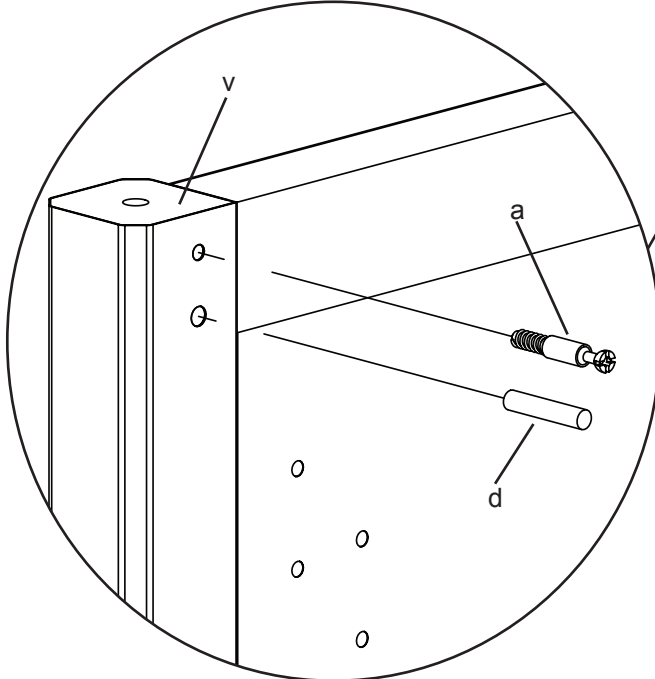
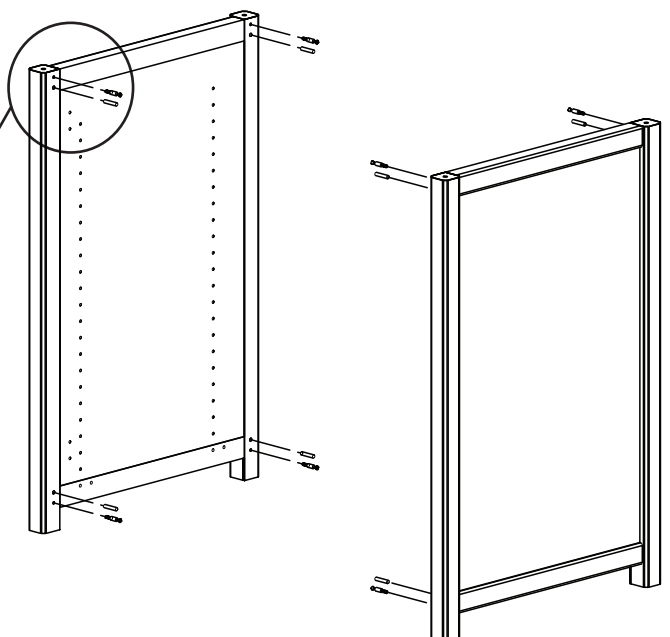
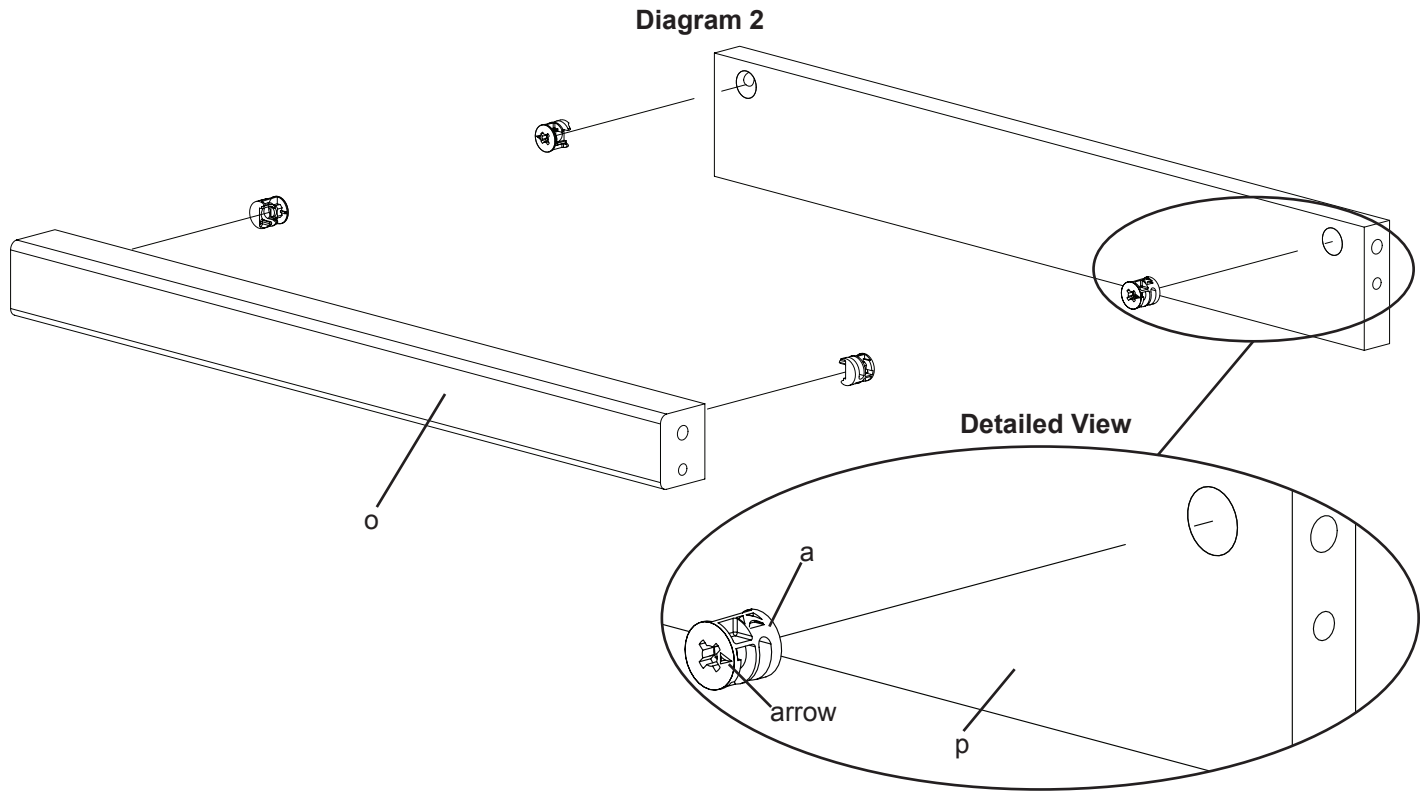

Diagram 1



Step 2: Prepare Stretchers

Add a Cam (b) to each Front Stretcher (o) and Back Stretcher (p). Make sure the arrow in each Cam faces the hole on the side of the Stretchers. See Diagram 2 for assistance.



Step 3: Add Stretchers

Add the Front and Back Stretchers (o,p) to the Side Panel (v), by aligning the Cam Pin (a) with the hole which the Cams (b) point to and the Dowel (d) goes into the adjacent hole. Make sure the stretchers are oriented so the Cams face inward. Tighten each Cam closest to the Side Panel in a clockwise motion until the stretchers are secured. **Note: Front stretchers attach to the same side as the hinge holes are on.**

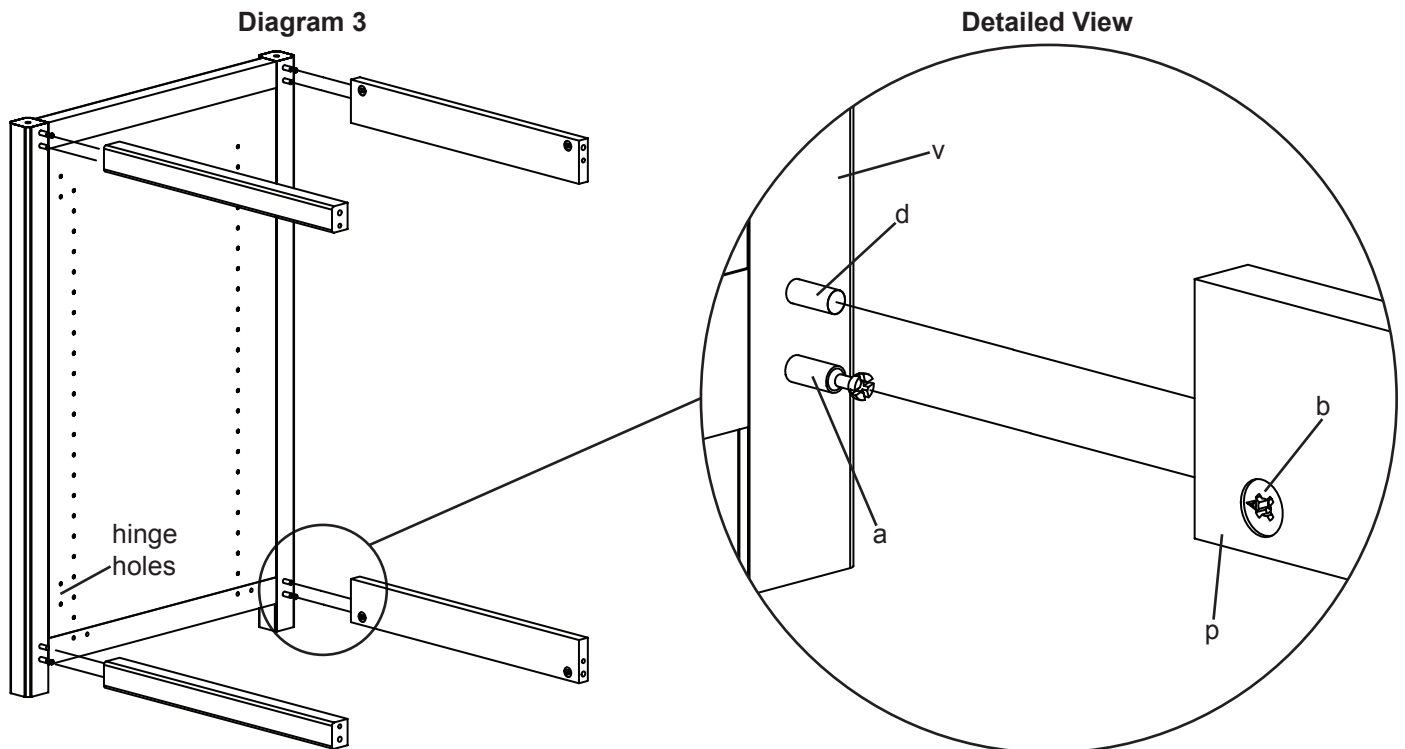

Step 4: Add Center Panel

Press fit the Center Panel (x) against the Stretchers (o,p) so the Cam Pin (a) goes into the hole which the Cams (b) point to. The Dowel (d) fits into the adjacent hole. Tighten each Cam in a clockwise motion until the Stretchers are secured to the Center Panel. See Diagram 4 for assistance. **Note: Make sure the hinge holes on the Center Panel are on the same side as the Front Stretchers.**

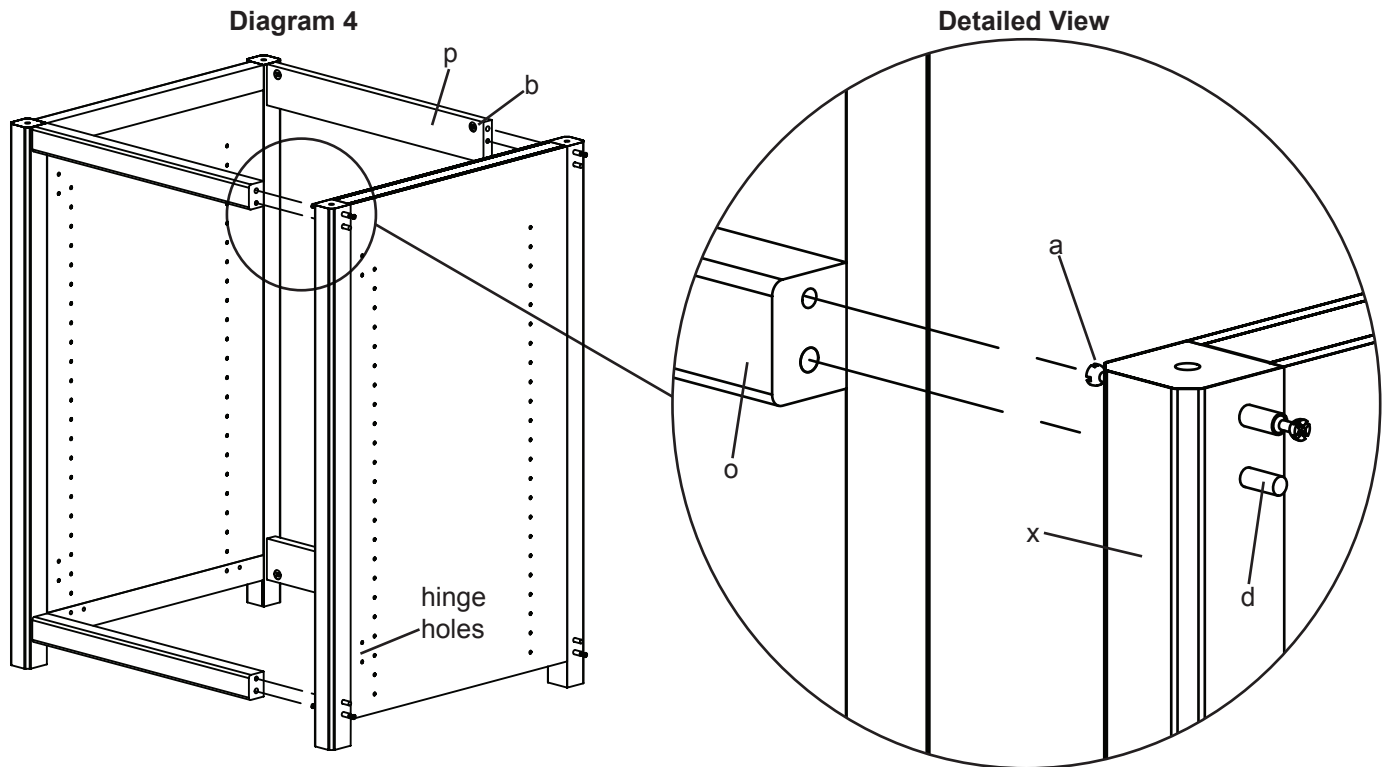

Step 5: Add Stretchers

Add the Front and Back Stretchers (o,p) to the Center Panel (x), by aligning the Cam Pin (a) with the hole which the Cams (b) point to. The Dowel (d) goes into the adjacent hole. Make sure the stretchers are oriented so the Cams face inward. Tighten each Cam closest to the Center Panel in a clockwise motion until the stretchers are secured. **Note: Front stretchers attach to the same side as the hinge holes are on.**

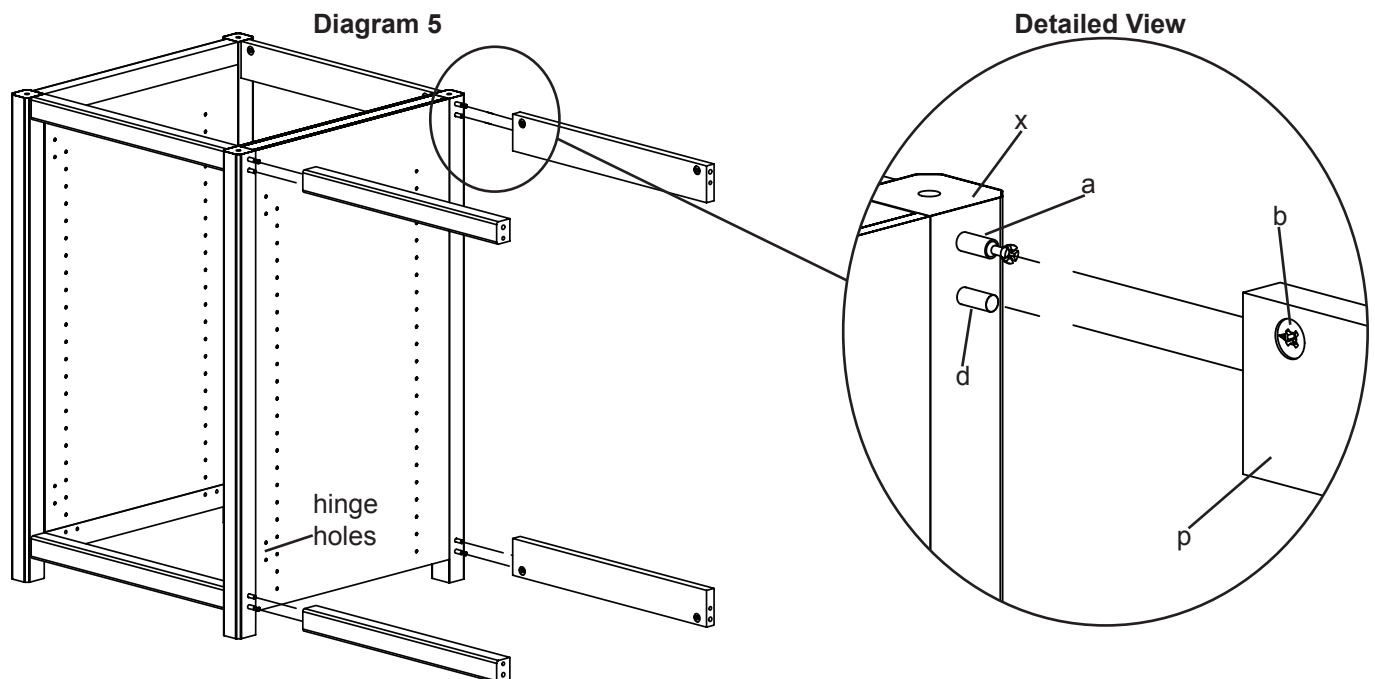

Step 6: Add Side Panel

Press fit the Side Panel (w) against the Stretchers (o,p) so the Cam Pin (a) goes into the hole which the Cams (b) point to. The Dowel (d) fits into the adjacent hole. Tighten each Cam in a clockwise motion until the Stretchers are secured to the Side Panel. See Diagram 6 for assistance. **Note: Make sure the hinge holes on the Side Panel are on the same side as the Front Stretchers.**

Diagram 6

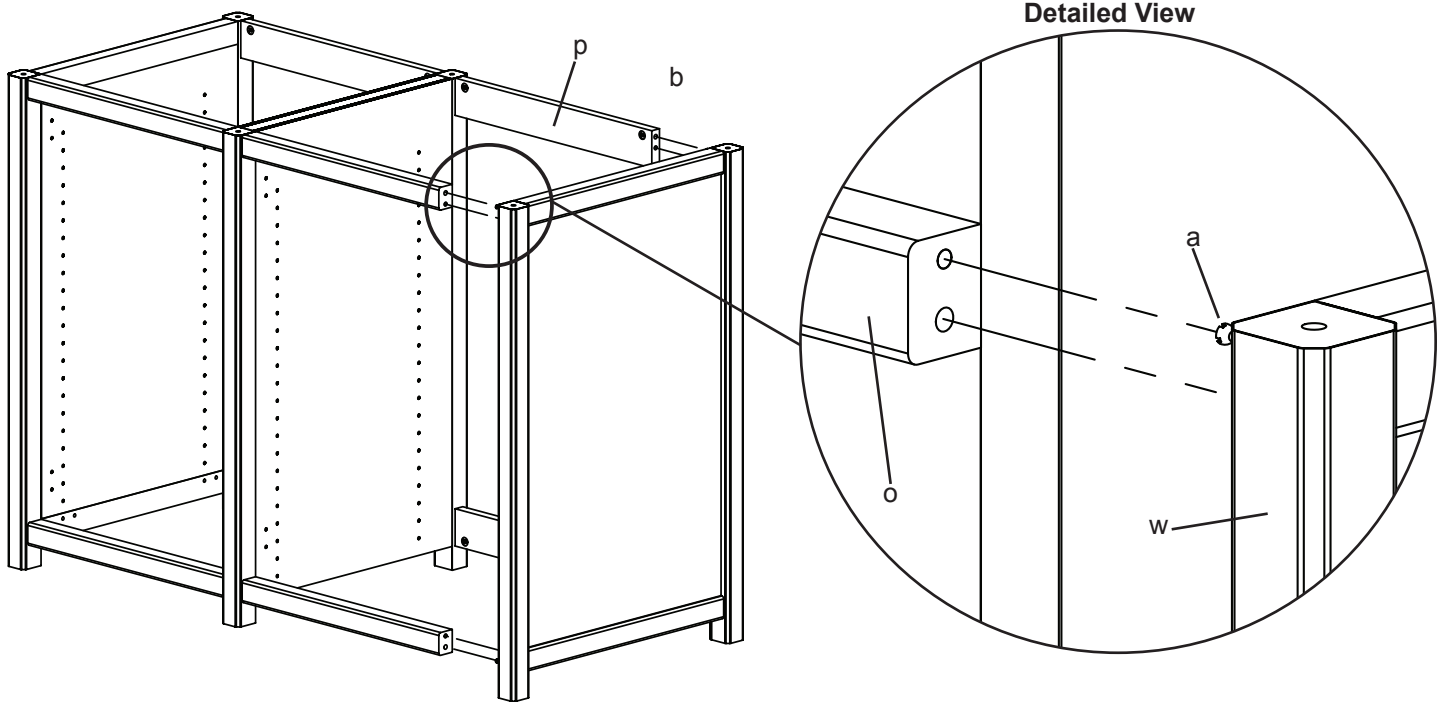

Step 7: Add Shelf Pins and Bottom Shelf

Thread the Shelf Pins (e) into the bottom hole in the line of holes in each Panel (v,w,x). Tighten Shelf Pins with a Phillips screw driver. Add the Bottom Shelf (q) by inserting it into the assembly and press fit it onto the Shelf Pins. Make sure the Bottom Shelf is flush against the Front Stretcher (o). If there is a gap in the front, the shelf may be backward. See Diagram 7 for assistance. Note: Diagram 7 is a Back View.

Diagram 7

Detailed View

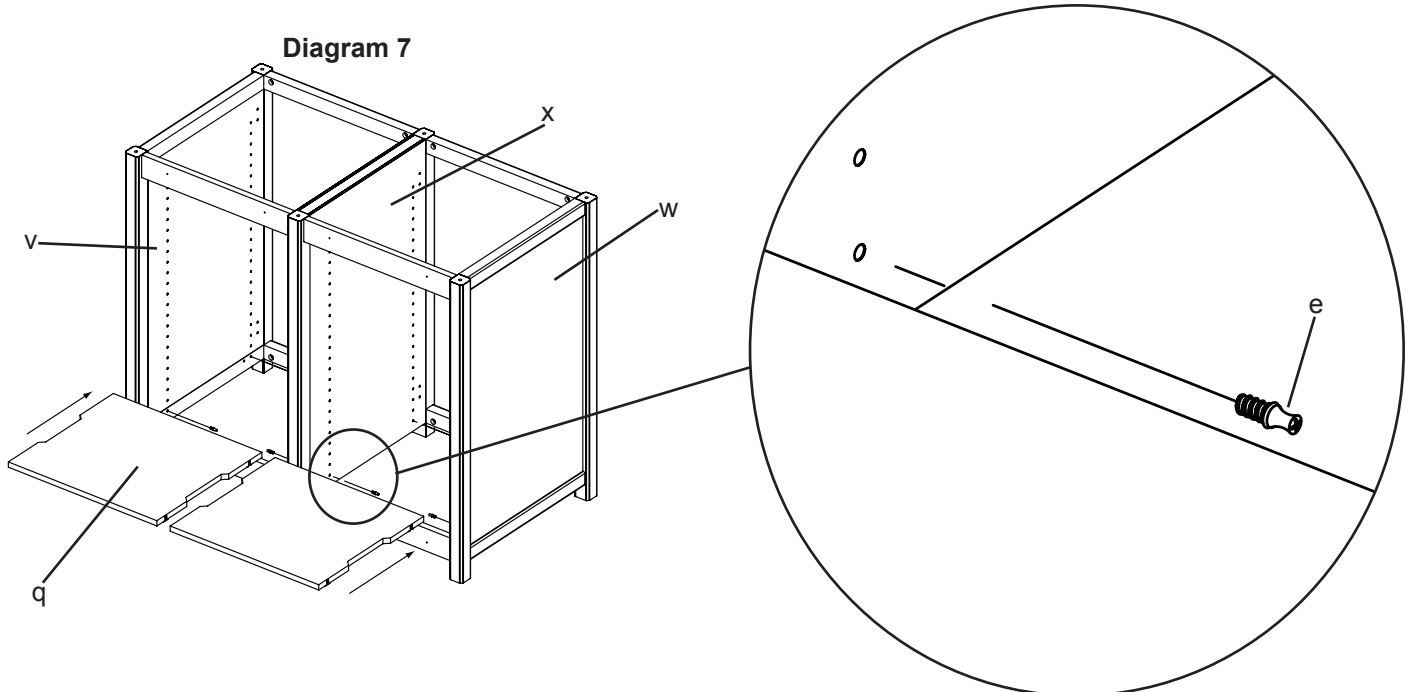

Step 8: Add Top

Gently tap a Dowel Pin (c) into the holes on the top of each Panel (v,w,x). Slide a Spacer (g) over each Dowel Pin. Press fit the Top (n) so it fits onto the Dowel Pins. See Diagram 8 for assistance.

Diagram 8

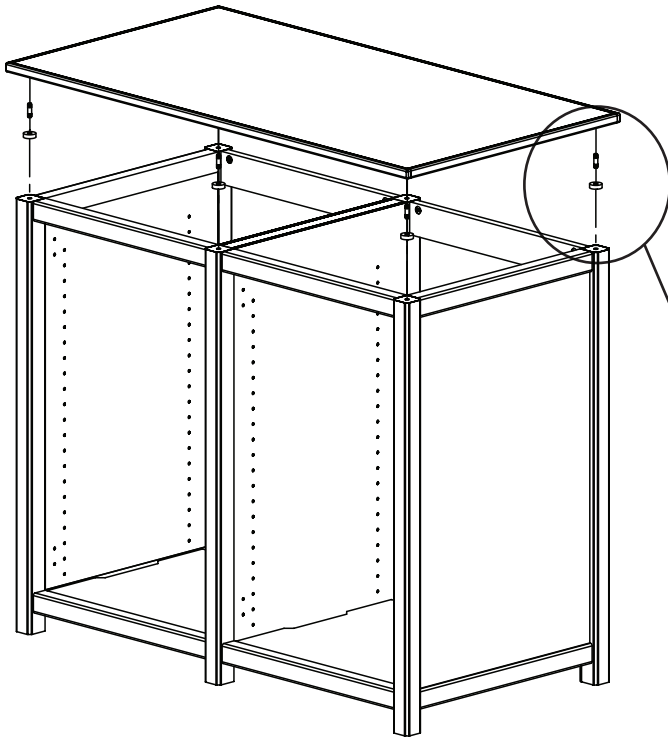

Detailed View

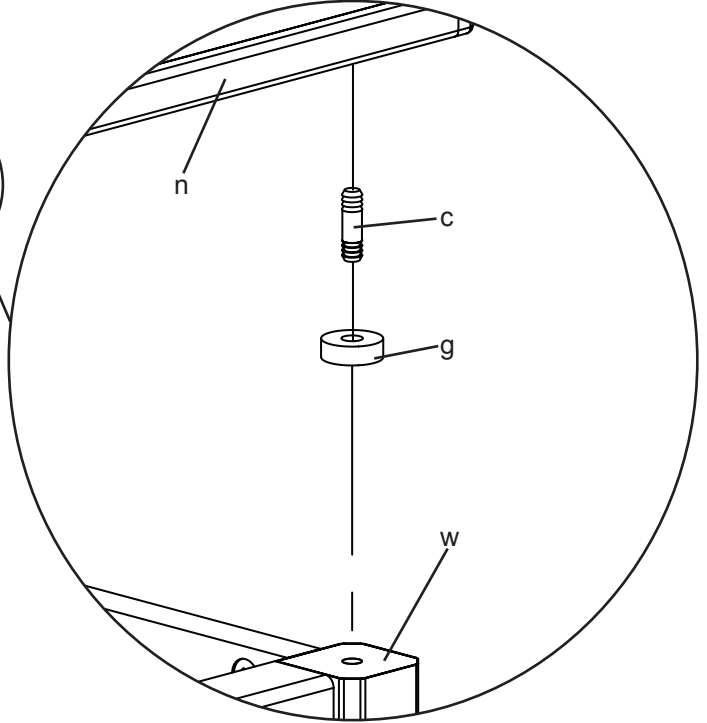

Step 9: Prepare Doors

Insert each Phillips Bolt (h) through the Door (s) and into the Door Handle (i). Tighten with a Phillips screw driver. See Diagram 9a for assistance. The Door Panels can be interchanged by removing and re-installing the plastic border from the perimeter of the Door's back side.

Insert a Hinge Screw (j) through the Hinge (l) and thread it into the Door (s). Tighten each with a Phillips screw driver. Repeat process until each Hinge Assembly is secure. See Diagram 9b for assistance.

Diagram 9a

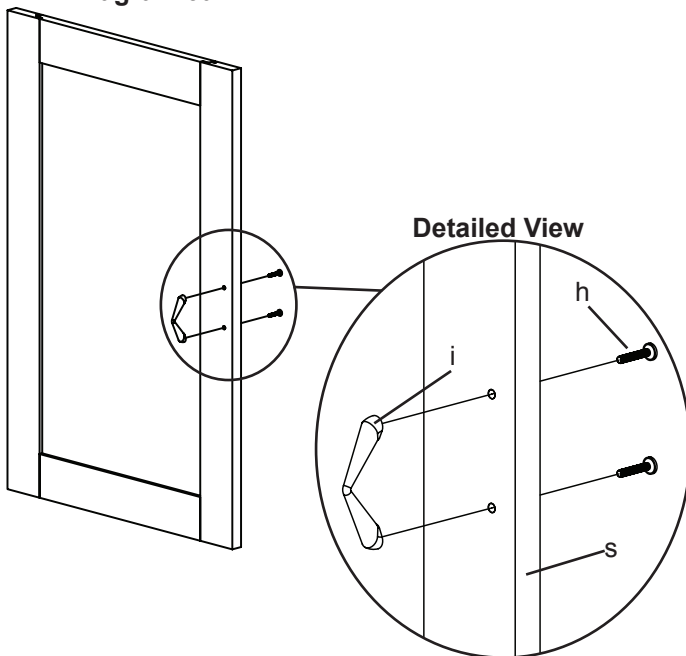

Detailed View

Diagram 9b

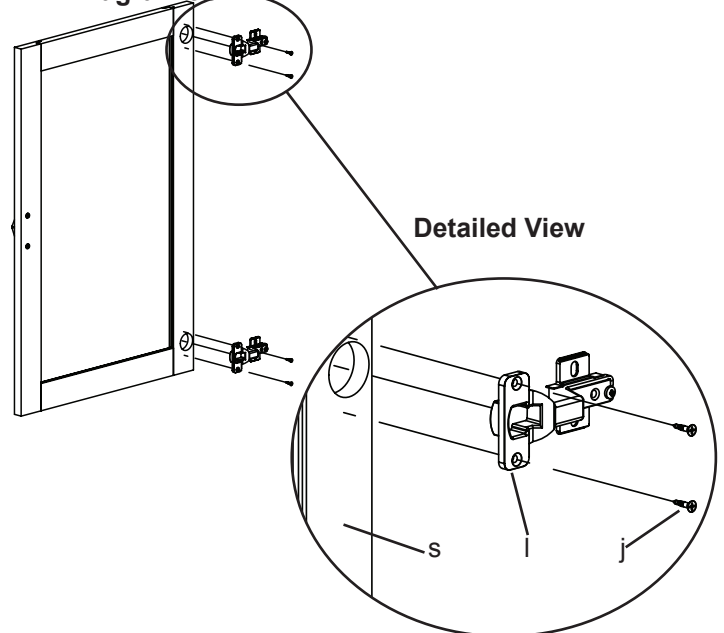

Detailed View

Step 10: Door Install

Position the Door (s) so the holes in the Hinge Plate (m) line up with the front pair of holes in the Side Panel (v,w). Insert a Hinge Plate Screw (k) through the Hinge Plate and thread it into each hole in the Side Panel. Tighten with a Phillips screw driver. Repeat process so each Hinge Assembly is secured. See Diagram 10 for assistance.

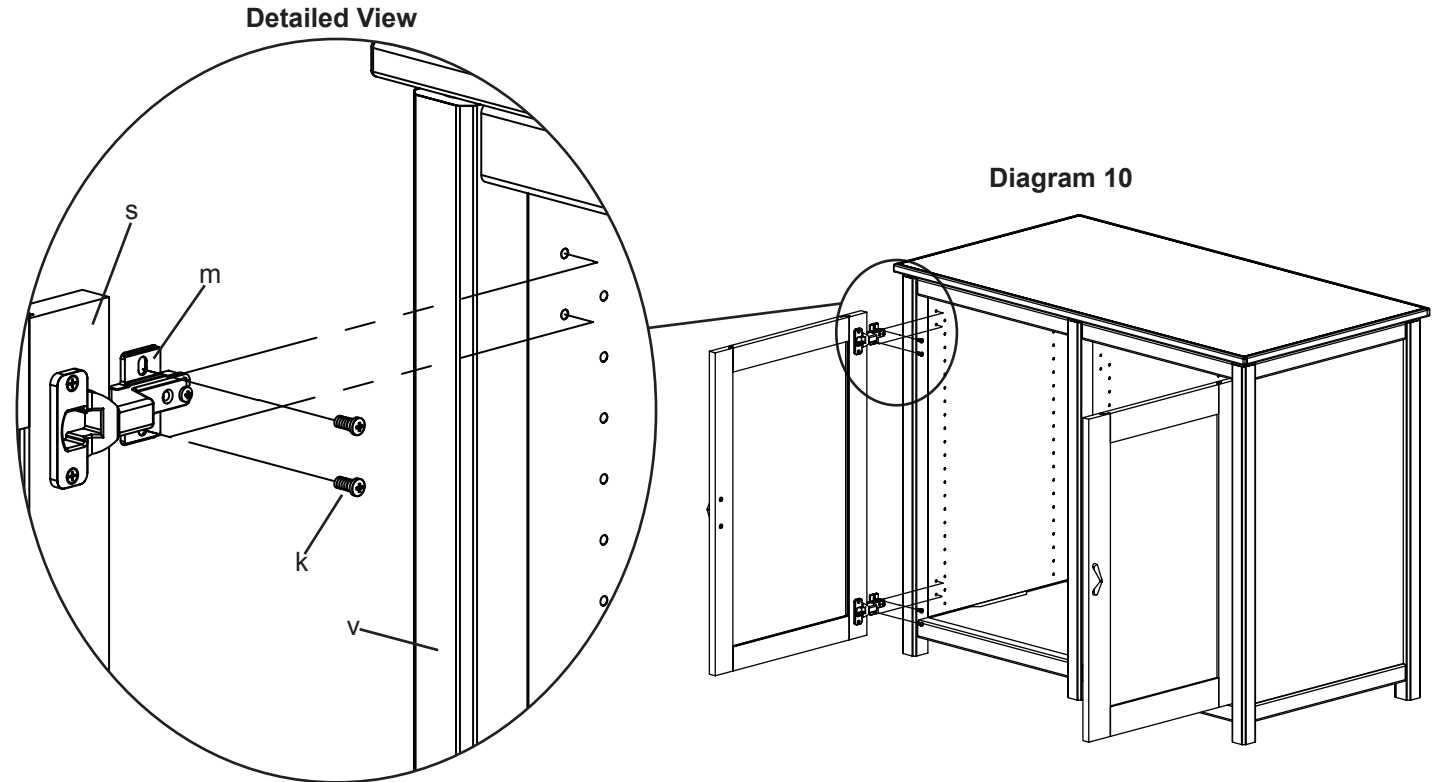

Step 10: Add Mid Shelves

Thread a Shelf Pin (e) into the desired location in the Panels (v,w,x). For each shelf, four Shelf Pins will be required. Insert each Mid Shelf (r) into the assembly and press fit onto the Shelf Pins. Make sure the wood strip on each shelf is facing toward the front. See Diagram 10 for assistance. Note: Diagram 10 is a Back View.

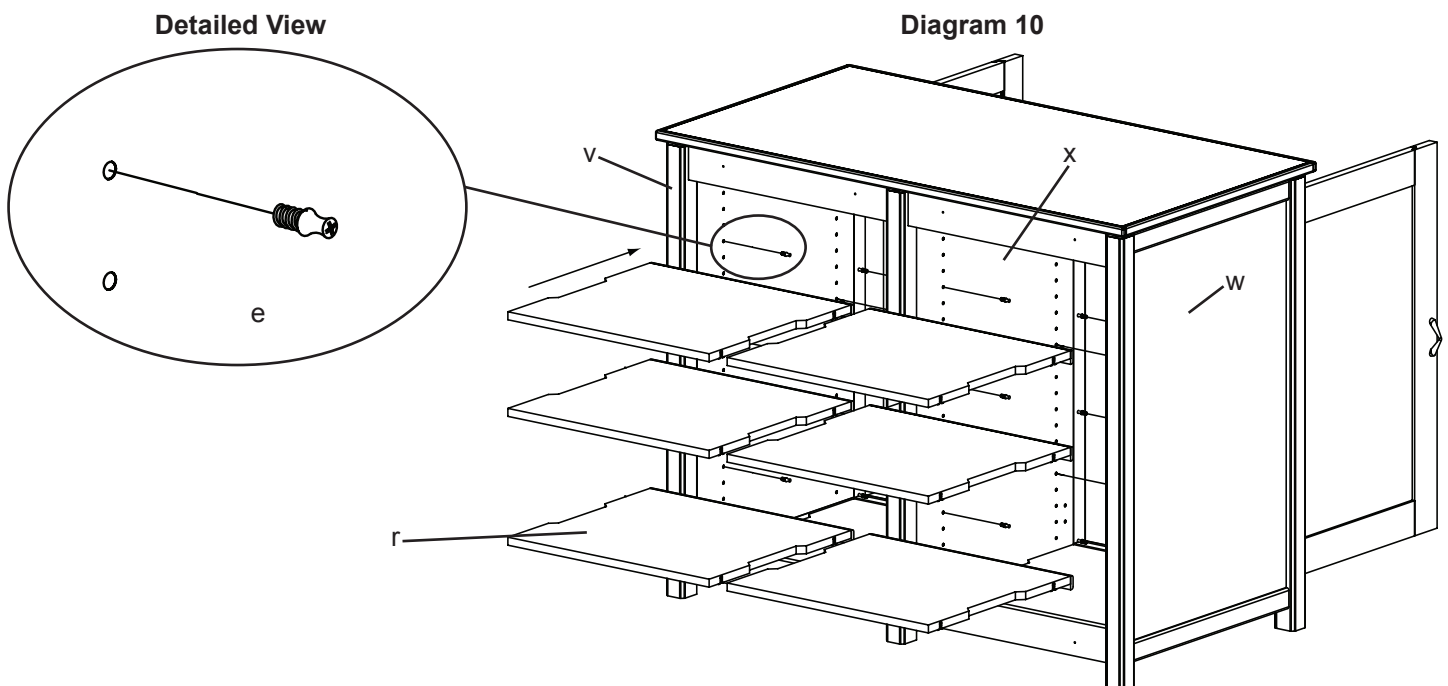

Step 11: Add Back Panel

Position each Back Panel (u) up against the assembly and thread a Wood Screw (f) through it and into the Back Stretcher (p). Repeat process until each Back Panel is secured with four Wood Screws. Tighten each with a Phillips screw driver. See Diagram 11 for assistance.

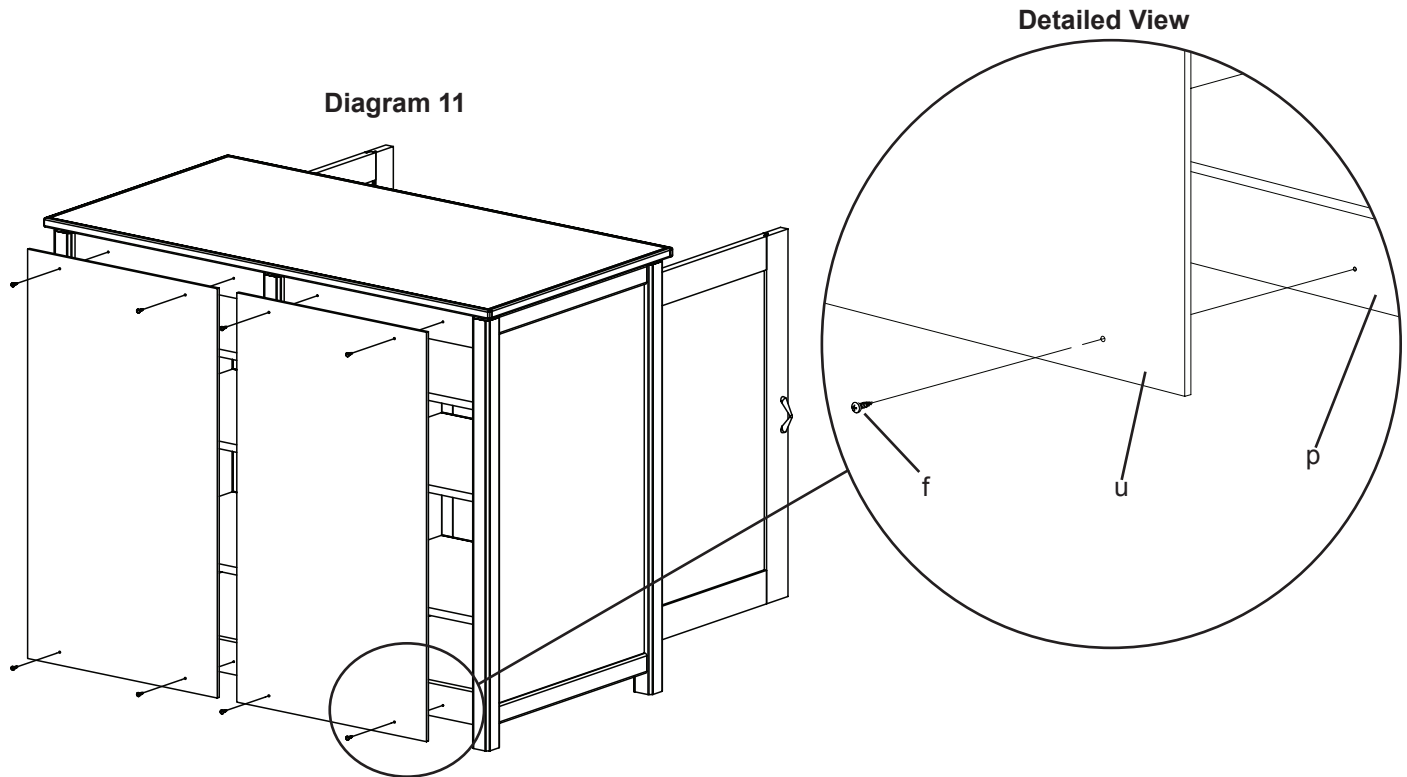

Step 12: Hinge Adjustment for Woodbrook Door

Each hinge Assembly is adjustable in multiple directions. See Diagram 12 for assistance.

Diagram 12

