

SANUS®

Basic Foundations

BFV846

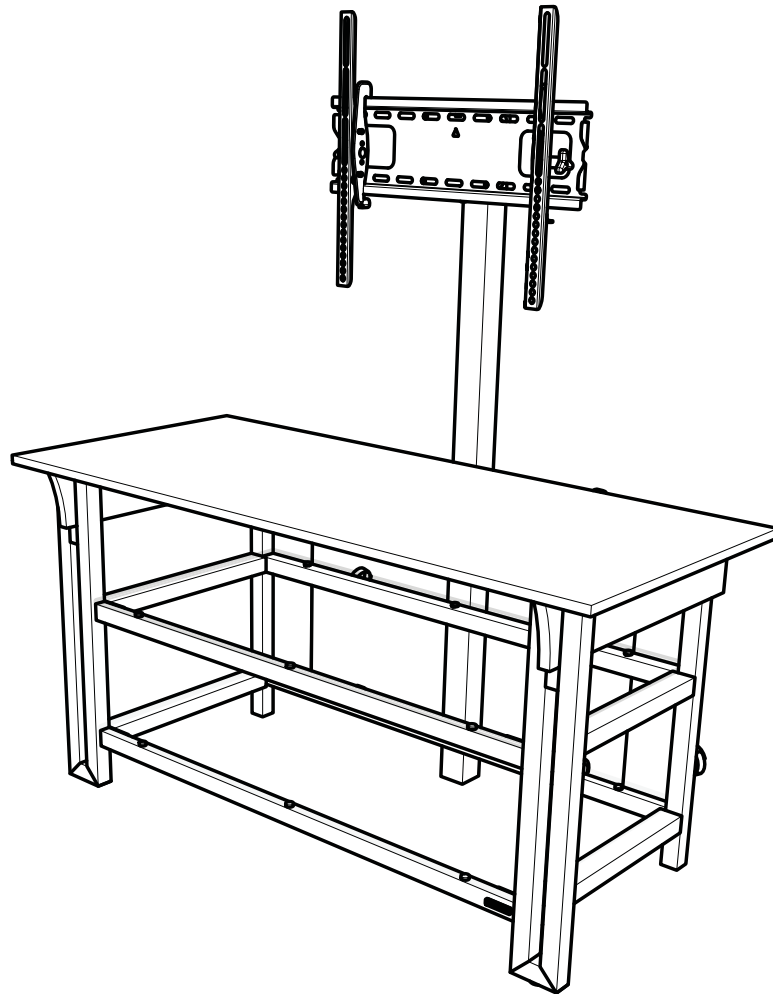

INSTRUCTION MANUAL

If you have any questions along the way, just give us a call.
1-800-359-5520. We're ready to help!



Before You Begin

⚠ CAUTION: Avoid potential personal injuries and property damage!

- Do not use this product for any purpose not explicitly specified by manufacturer
- If you do not understand these instructions, or have doubts about the safety of the installation, assembly or use of this product, contact Customer Service or call a qualified contractor
- Manufacturer is not responsible for damage or injury caused by incorrect assembly or use

Weight Limits

Without Pillar Kit

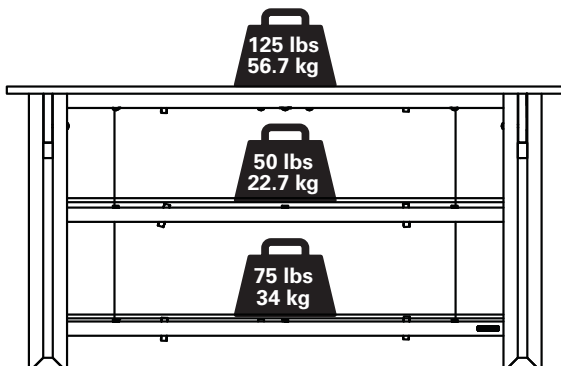

With Pillar Kit

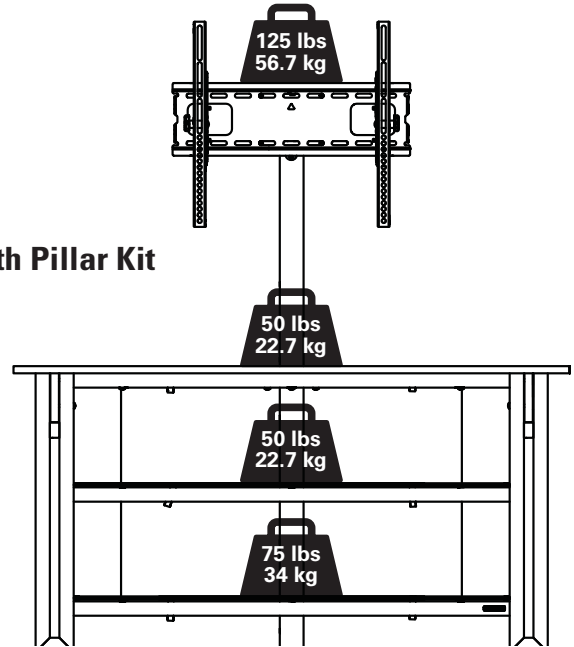

Cautions and Care

⚠ CAUTION: Avoid potential personal injuries and property damage!

- Tempered glass has been chosen for this product because of its strength and safety characteristics. However, tempered glass should still be handled with care to avoid possible property damage or personal injury.
- Mishandling during shipping, assembly, or use may result in damage that can weaken the tempered glass.
- Periodically check the glass to look for chips, cracks, or deep scratches.
- If chips, cracks, or deep scratches are found, discontinue use and contact customer service.

CARE INSTRUCTIONS

For wood with a natural finish, dust regularly with a soft dry cloth. When needed, wipe with a clean, damp, cloth and wipe dry.

⚠ CAUTION: This product is designed for use with flat panel TV's **ONLY**.

To prevent tipping, be sure to center your flat panel TV (NO CRT's) on the top of your furniture.

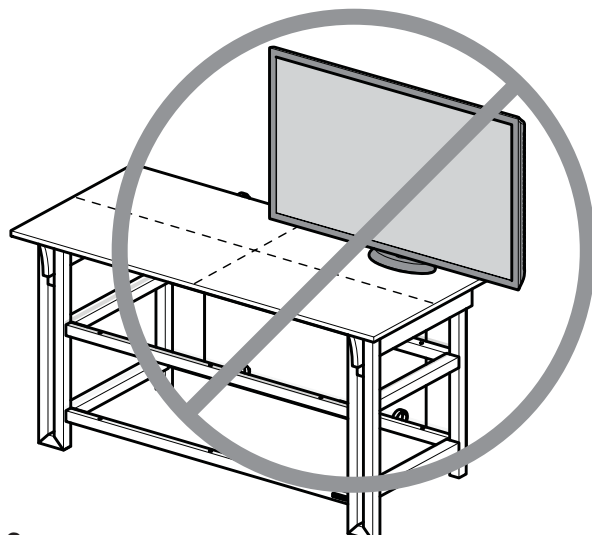
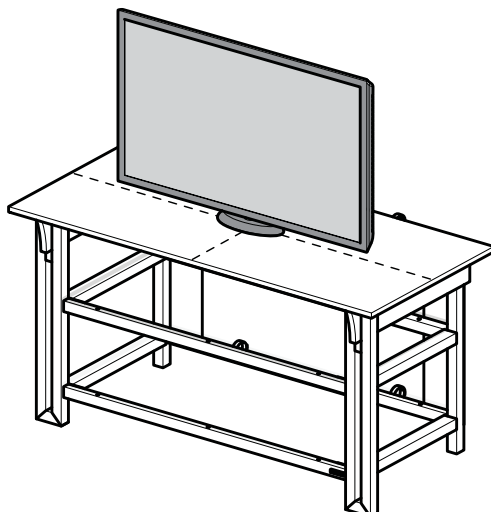

Required Tools

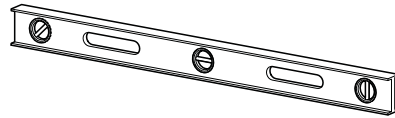
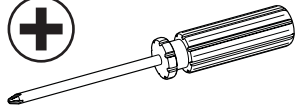

Supplied Parts and Hardware

⚠ WARNING: This product contains small items that could be a choking hazard if swallowed. Before starting assembly, verify all parts are included and undamaged. If any parts are missing or damaged, do not return the damaged item to your dealer; contact Customer Service. Never use damaged parts!

Table Parts and Hardware

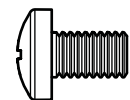
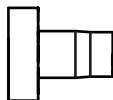
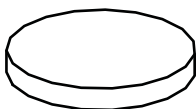
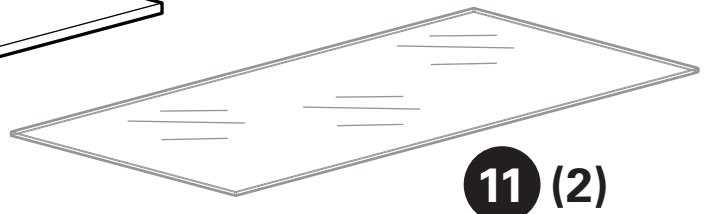
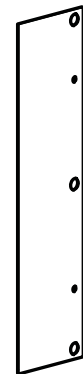
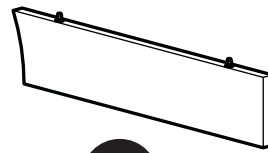
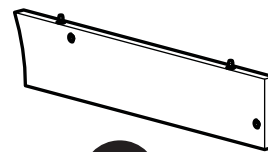
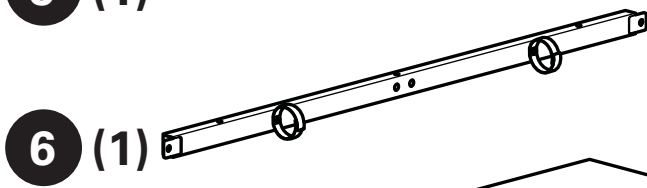
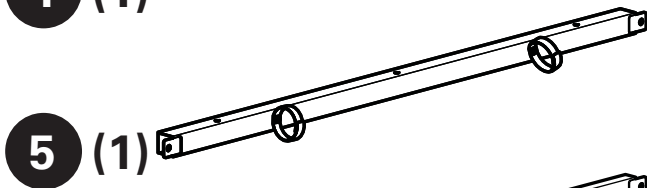
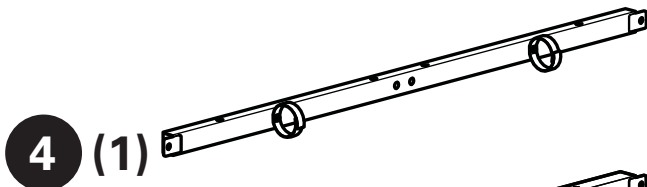
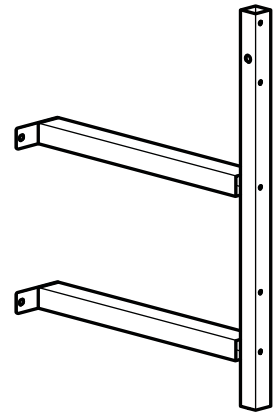
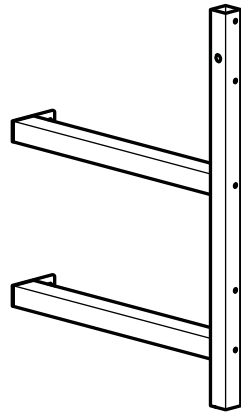
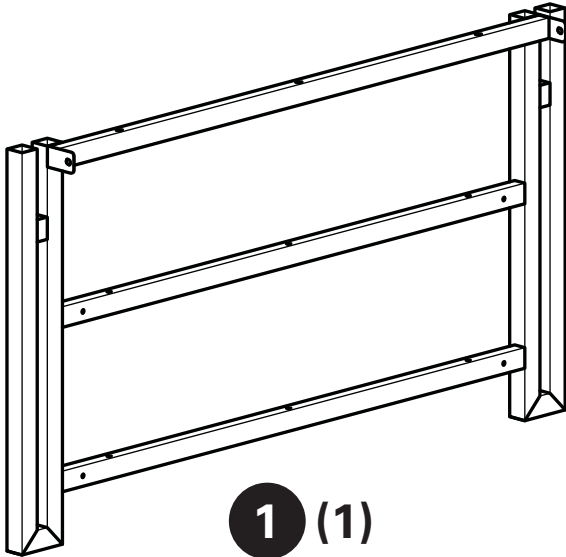

3 **14 (9)**

15 (16)

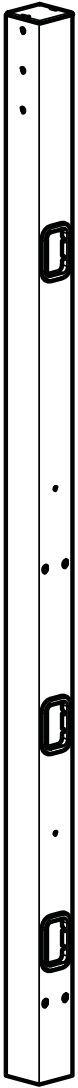

16 (1)

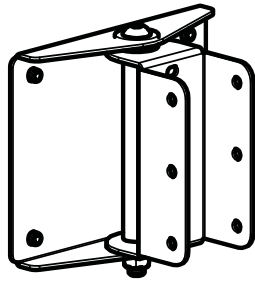

17 (1)

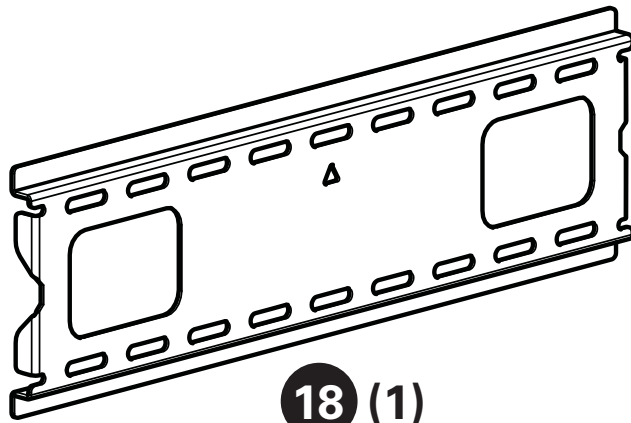

18 (1)



19 (1)

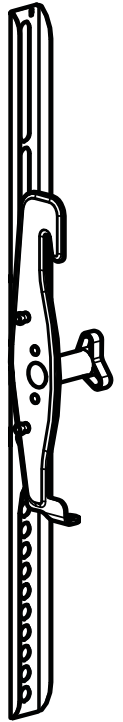

20 (1)

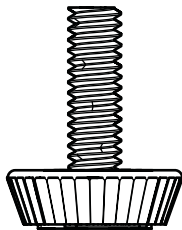

21 (1)



M5 x 16mm

22 (4)

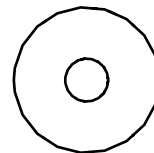

23 (4)

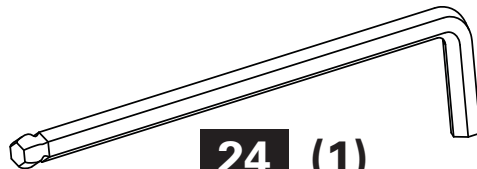

24 (1)



M4 x 5mm

25 (2)

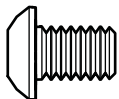

1/4-20 x 3/8 in.

26 (6)



M5 x 40mm

27 (2)

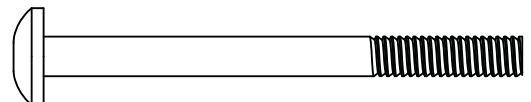

1/4-20 x 2 1/2 in.

28 (4)

TV Mounting Hardware

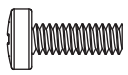

M4 x 12mm

29 (4)



M4 x 35mm

30 (4)

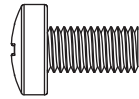

M6 x 12mm

31 (4)

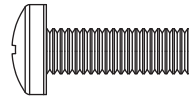

M6 x 20mm

32 (4)

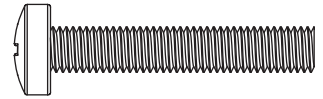

M6 x 35mm

33 (4)

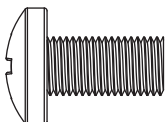

M8 x 16mm

34 (4)

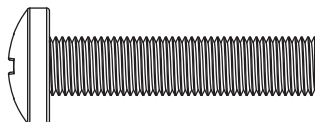

M8 x 35mm

35 (4)

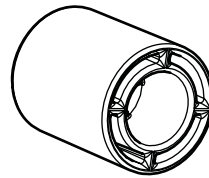

36 (4)

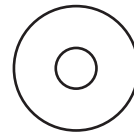

M4

37 (4)

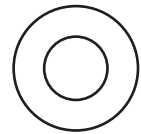

M6/M8

38 (4)

Anti-tip Restraint Kit

39 (1)

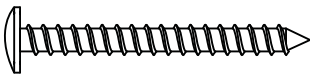

#8 x 39 mm

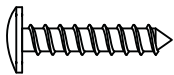

#8 x 19 mm

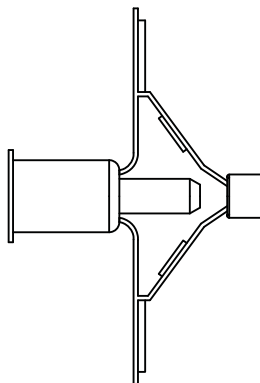

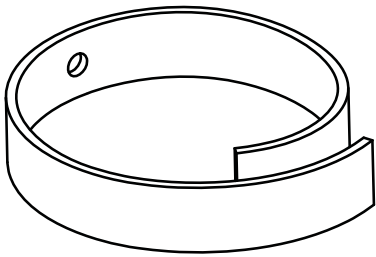

40 (6)

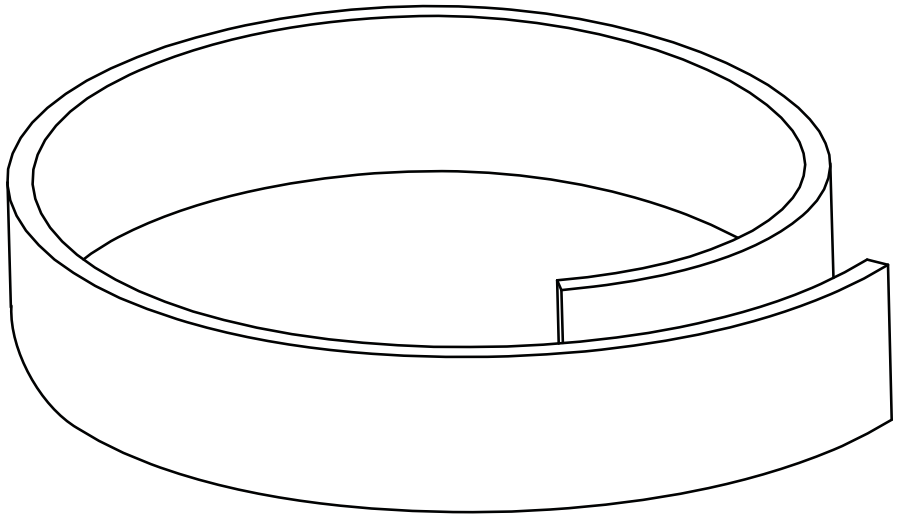

41 (2)

Dimensions

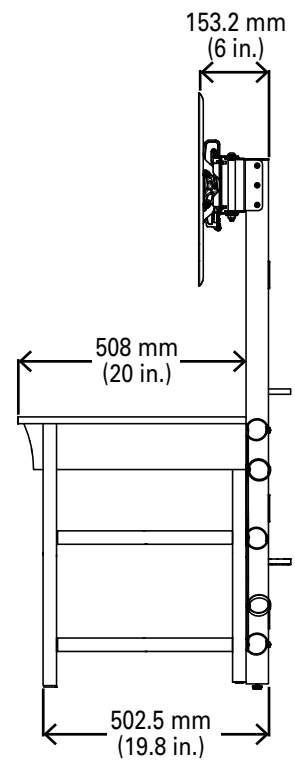
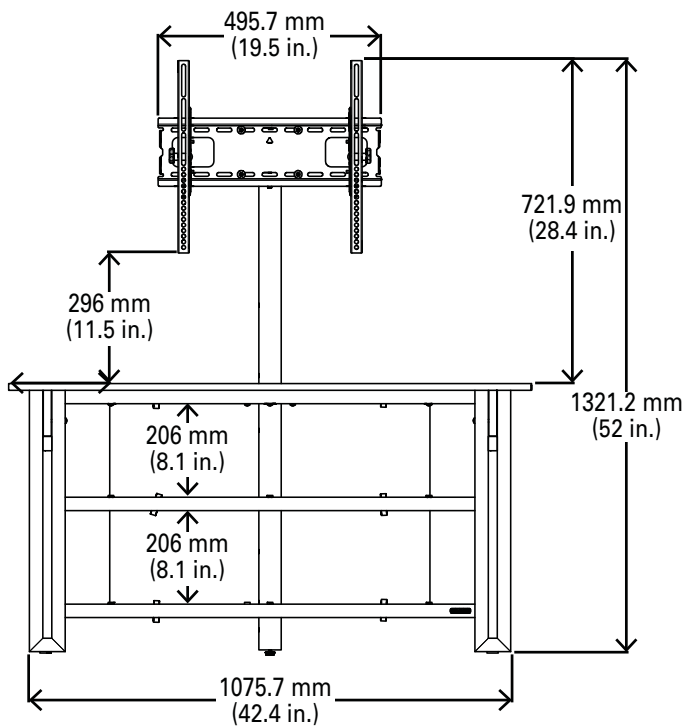
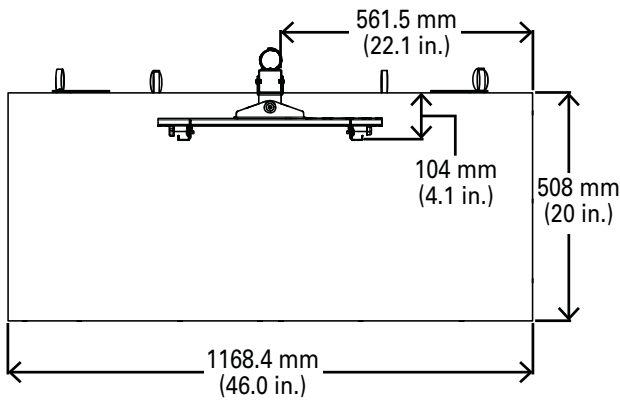

Wall Mounting **OPT**

Required Tools

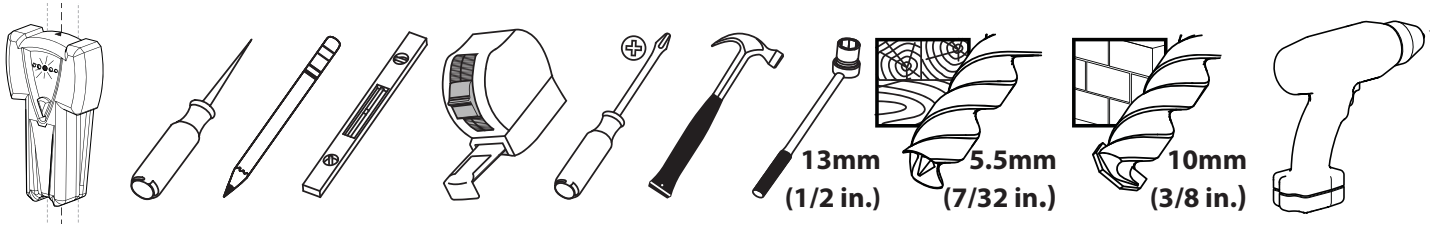

Supplied Parts and Hardware

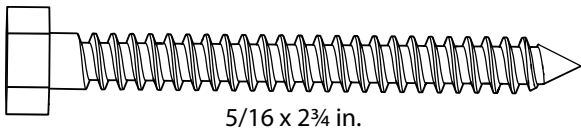

42 (4)

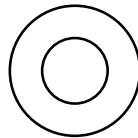

43 (4)

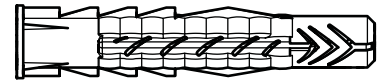

44 (4)

Step 1

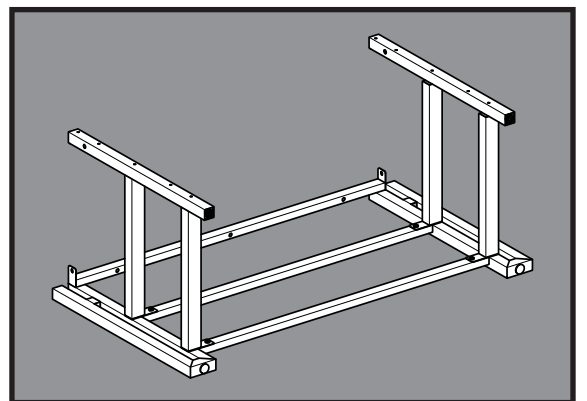
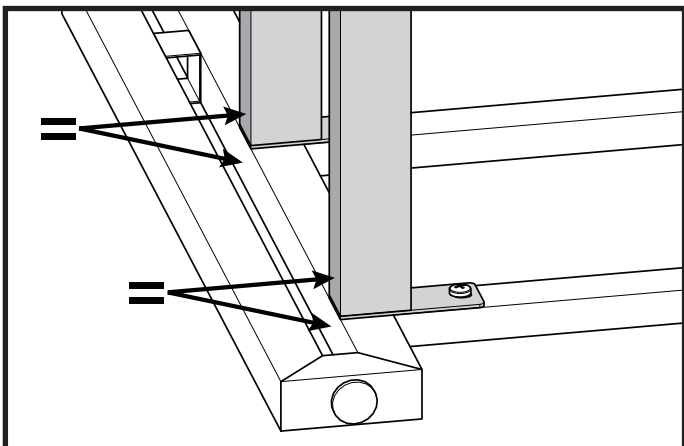
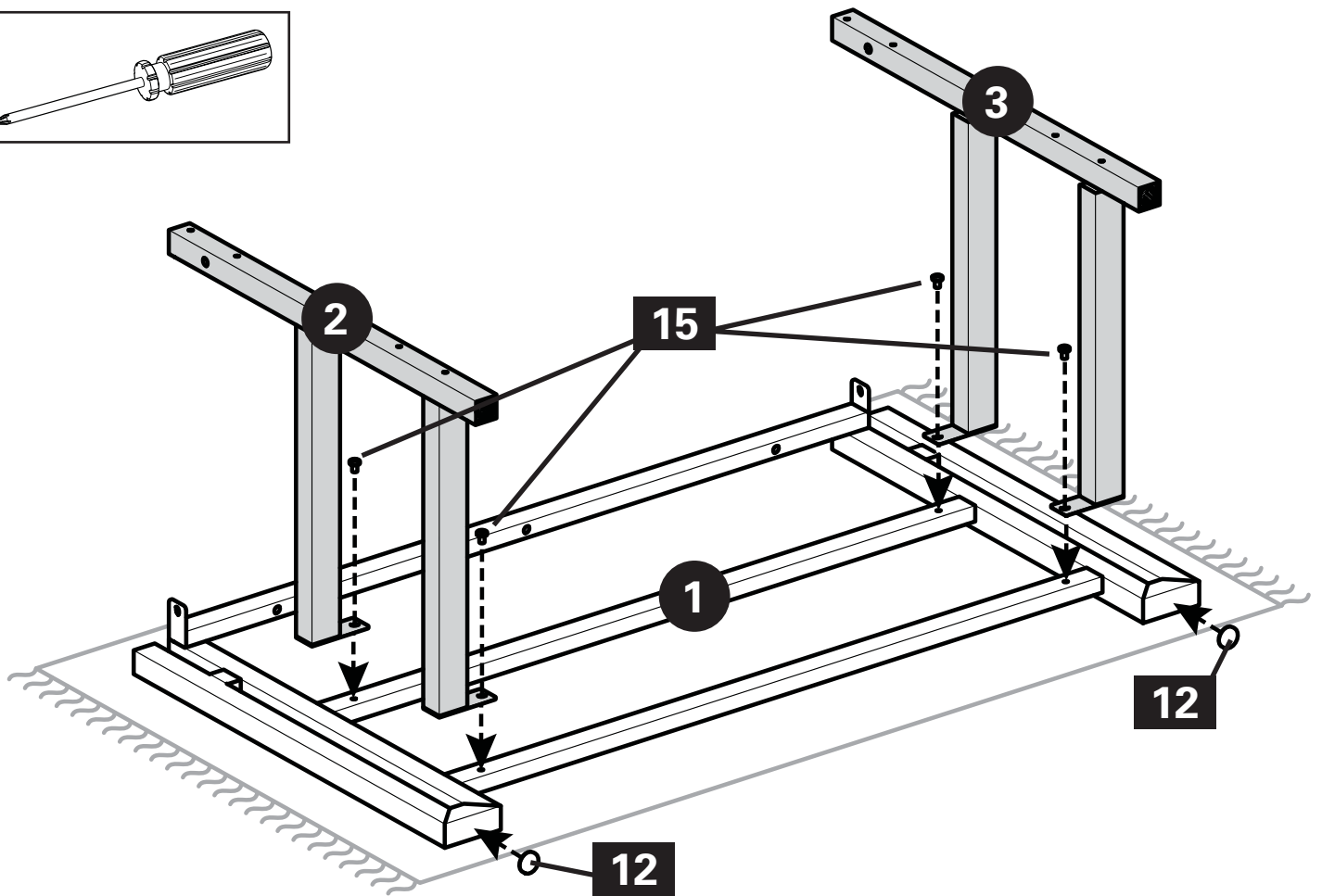
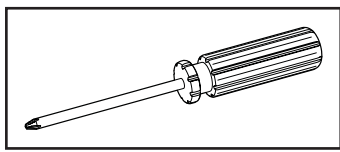
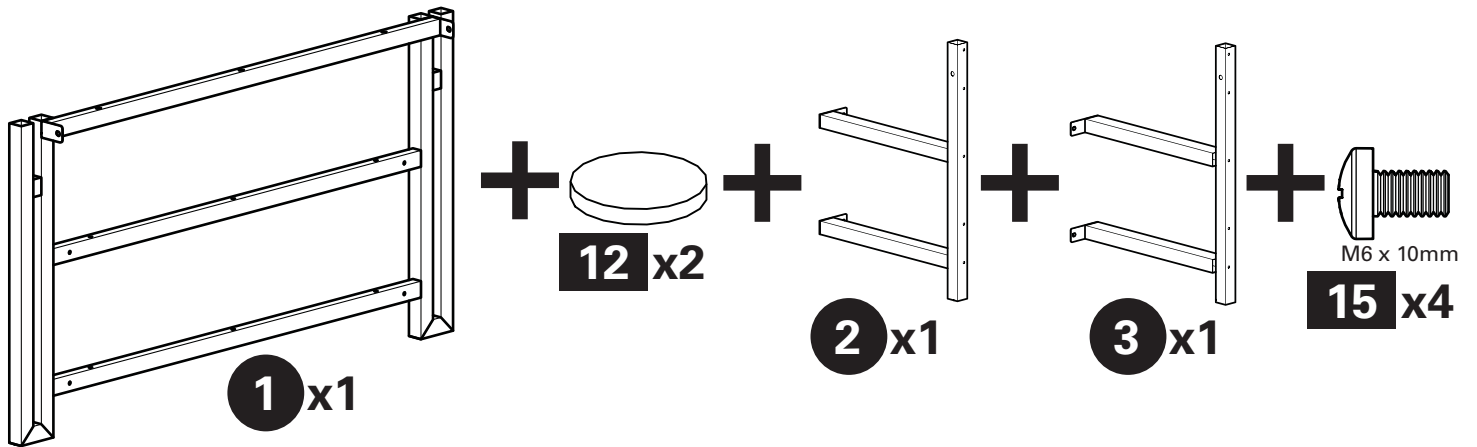

Step 2

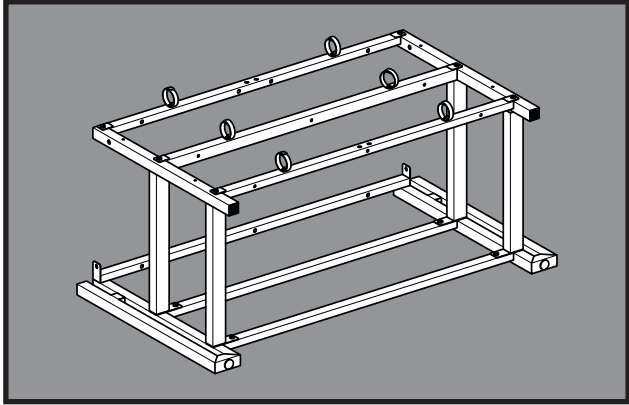
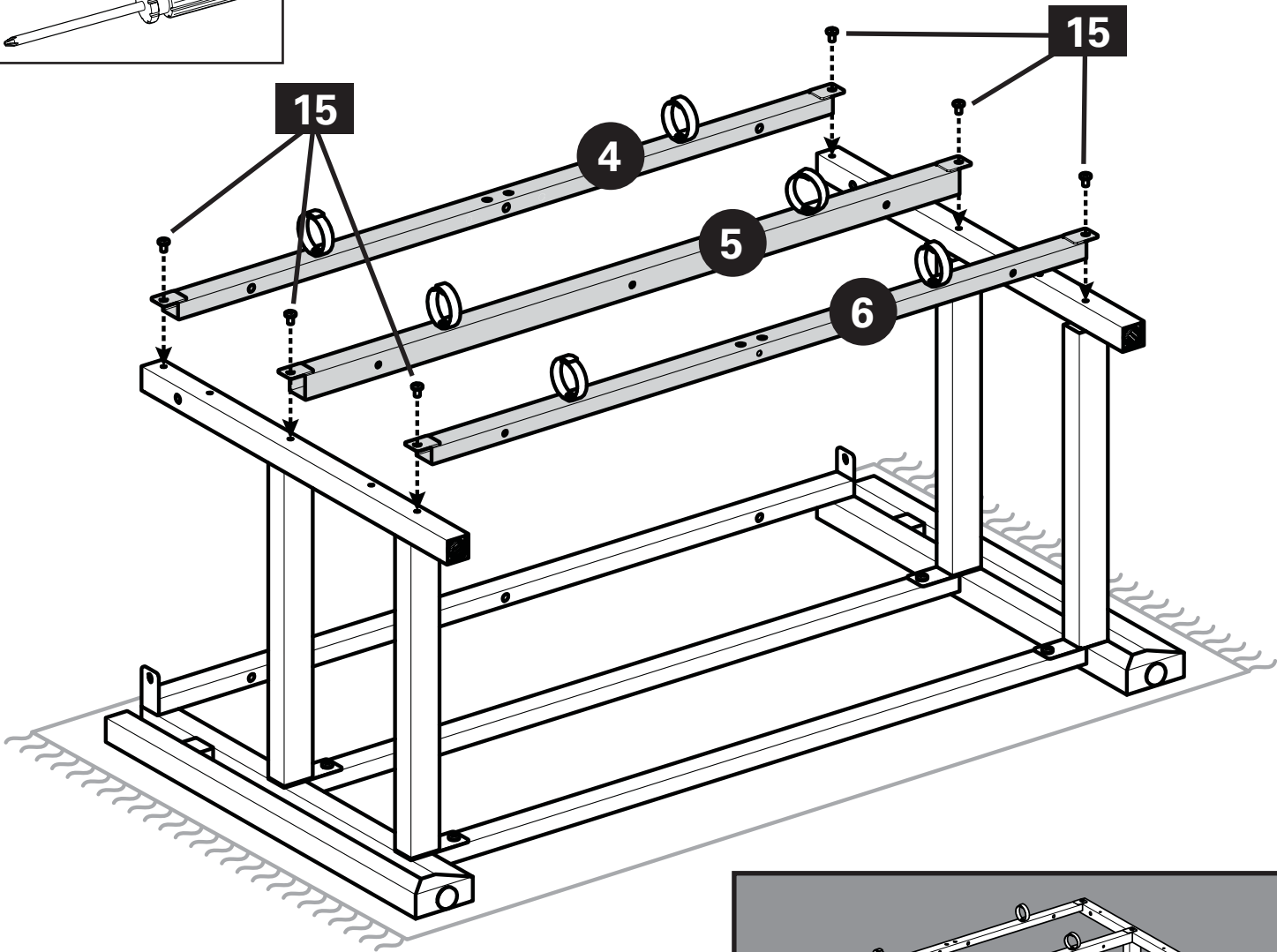
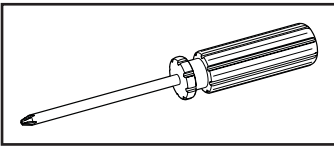
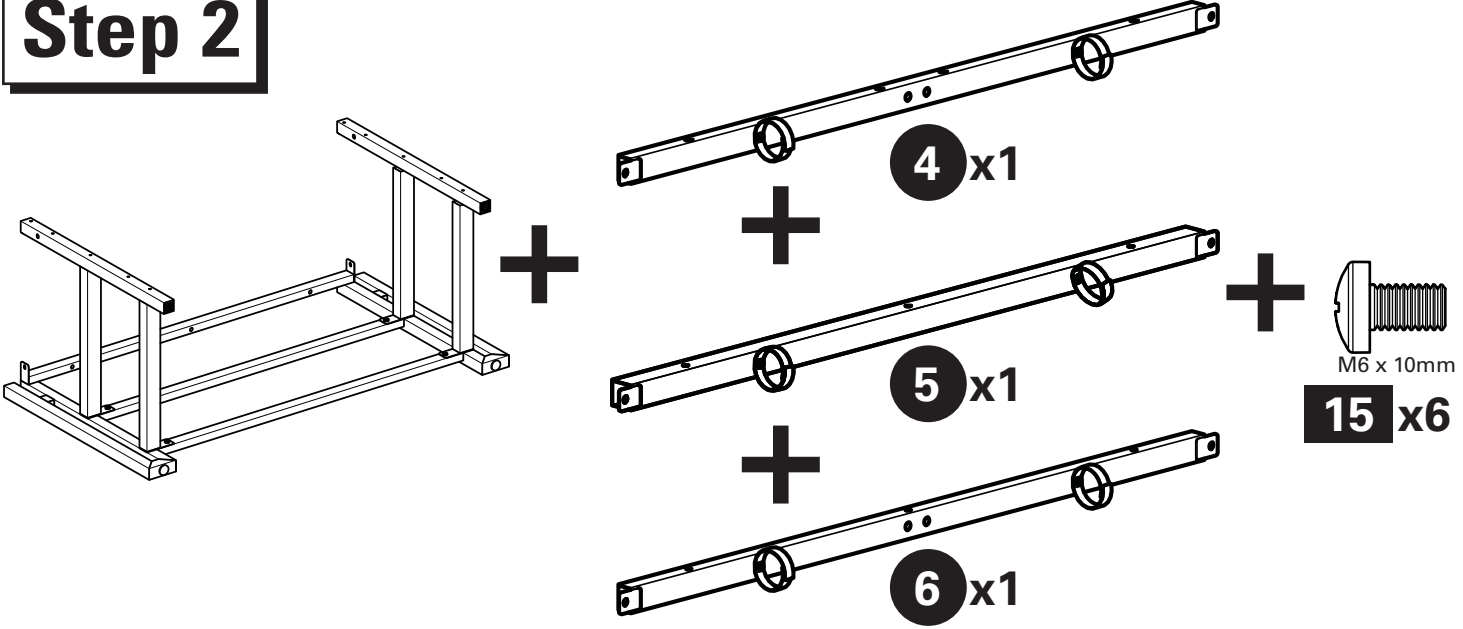

Step 3

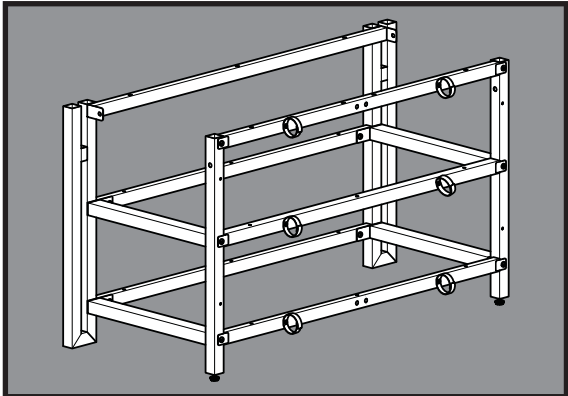
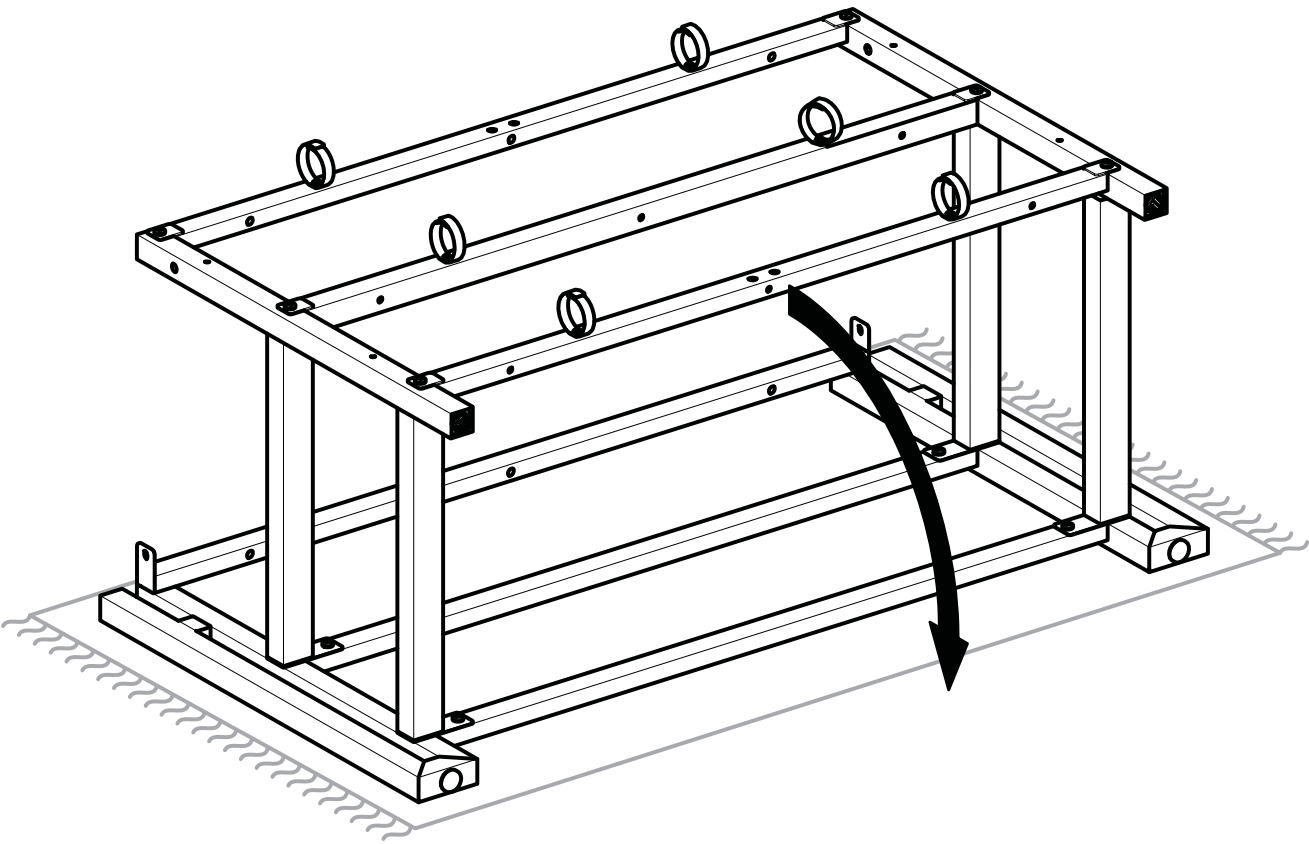
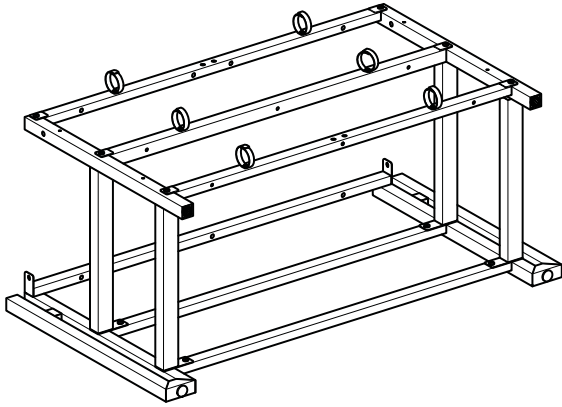

Step 4

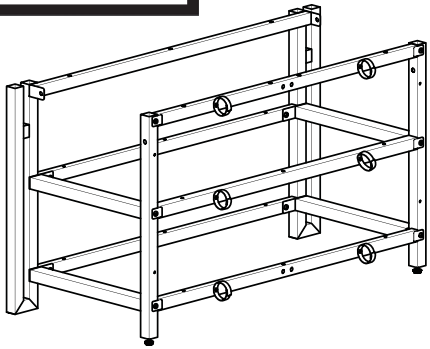

+



7 x1

+



8 x1

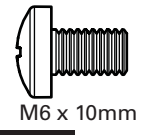

M6 x 10mm

15 x2



M6 x 40mm

14 x2

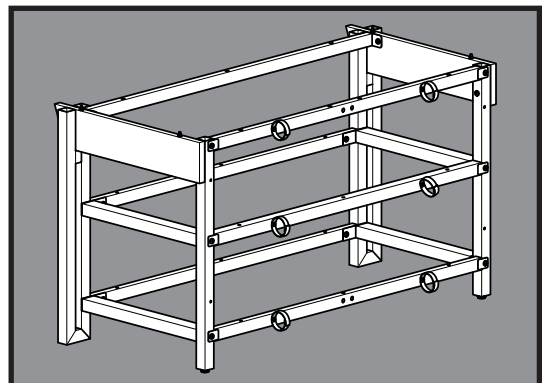
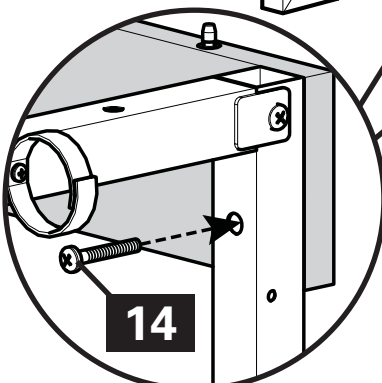
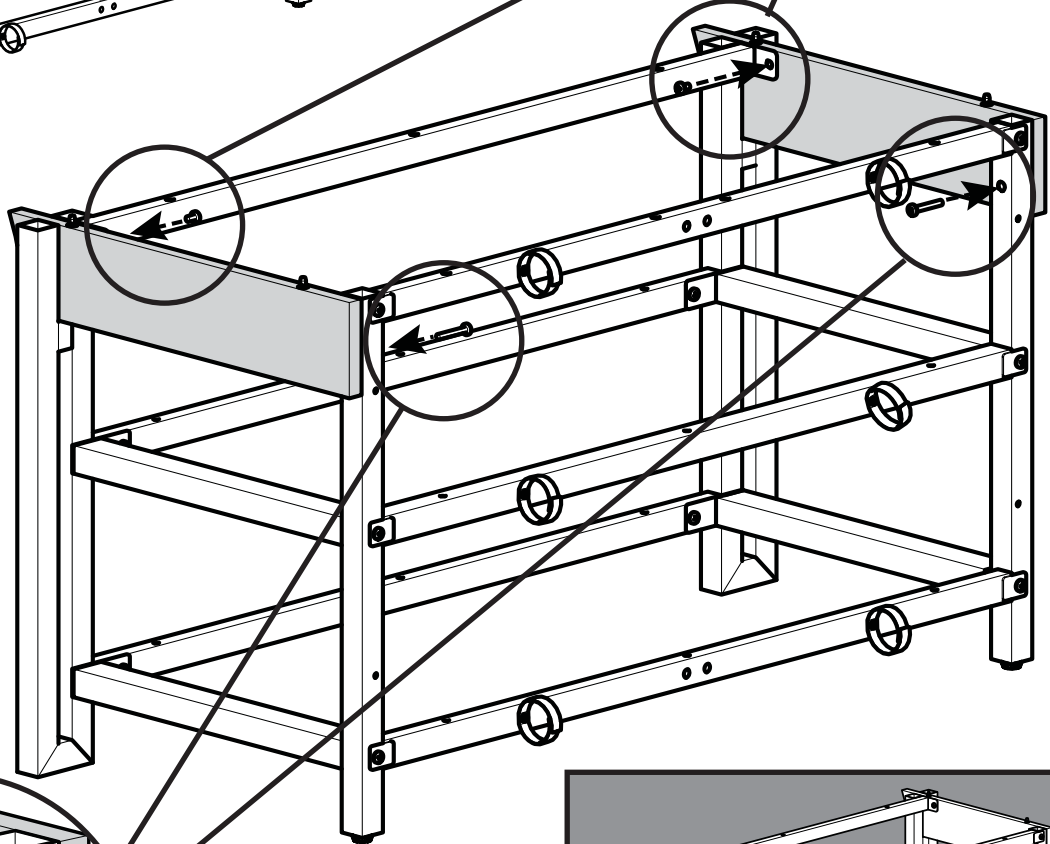
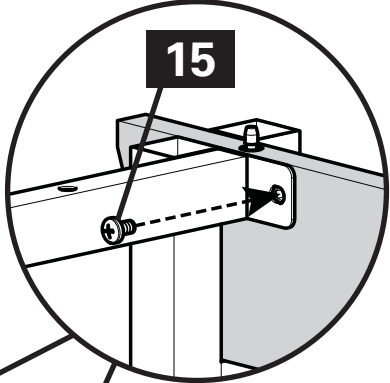
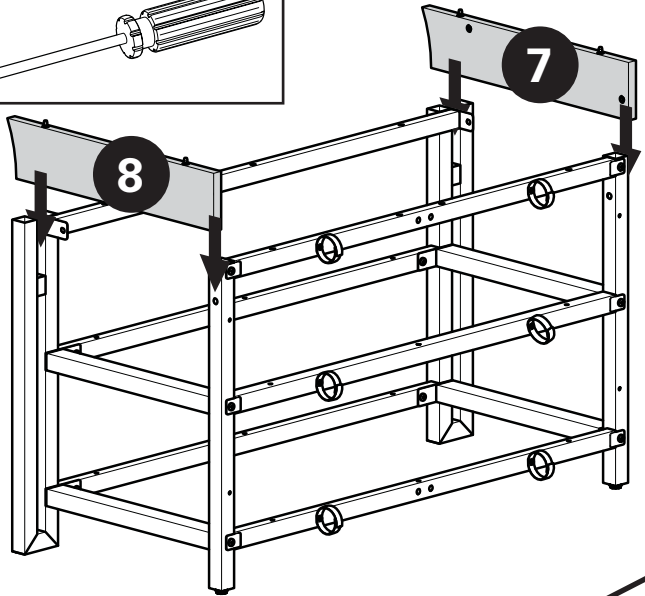
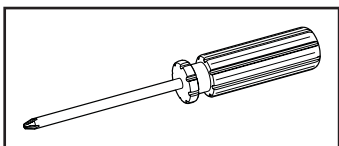

Step 5

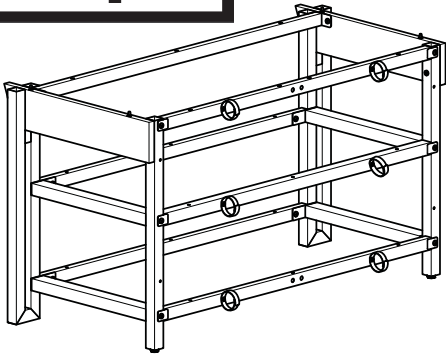

+

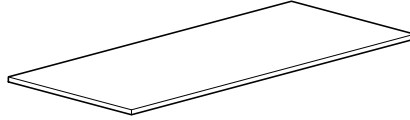

10 x 1

+



M6 x 40mm

14 x 7

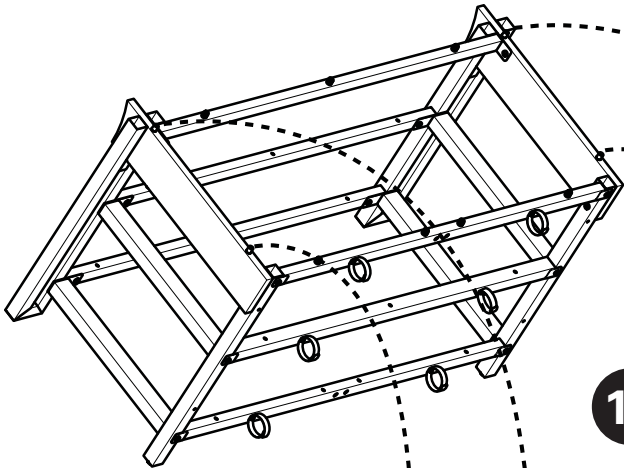

You will need assistance with this step.

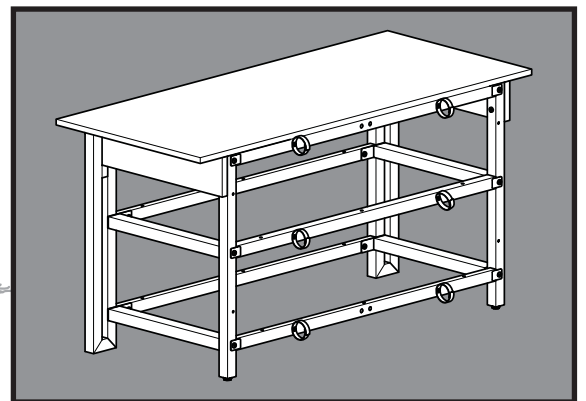
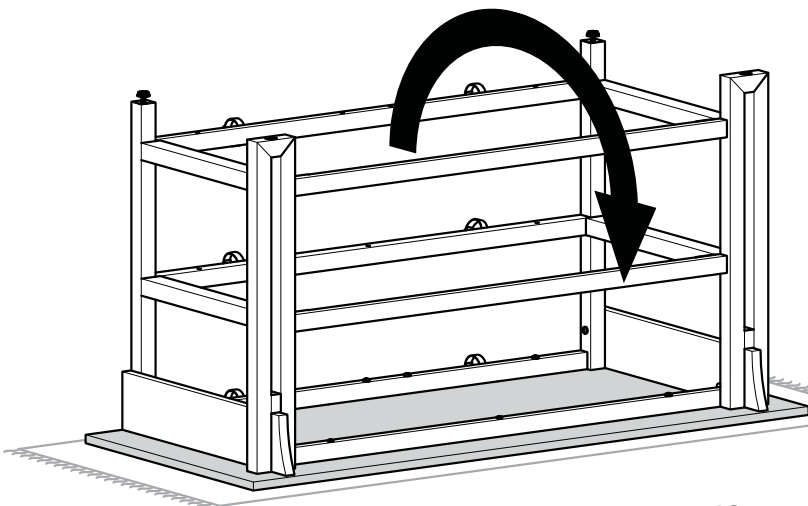
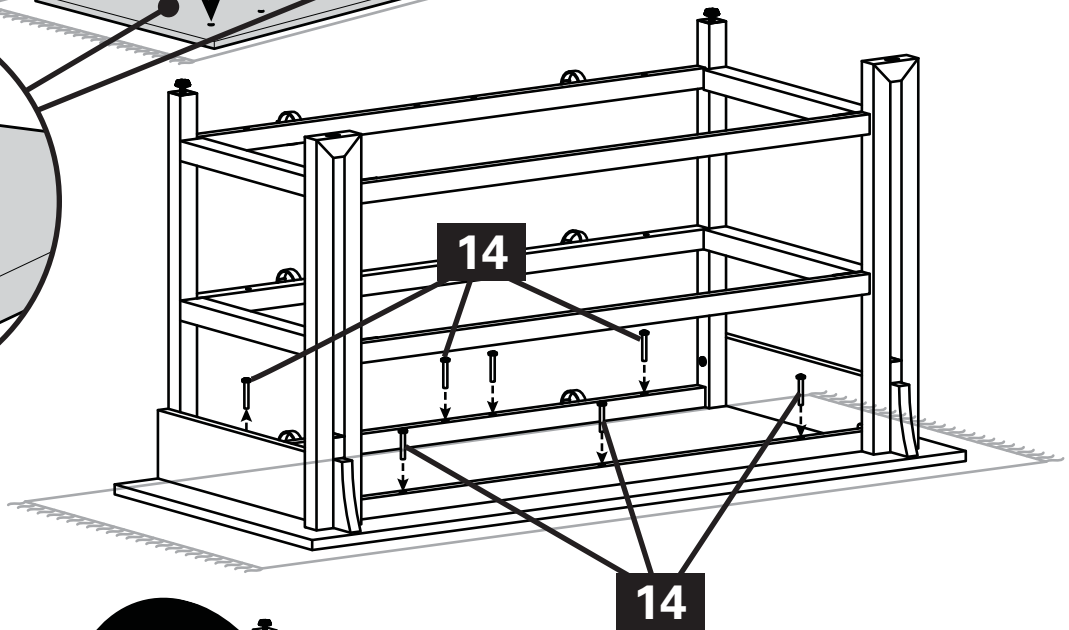
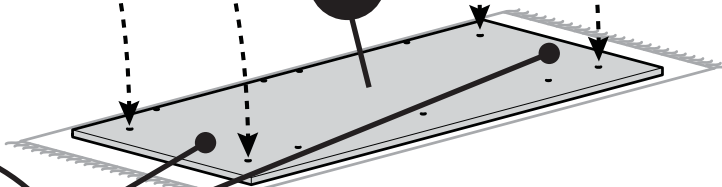
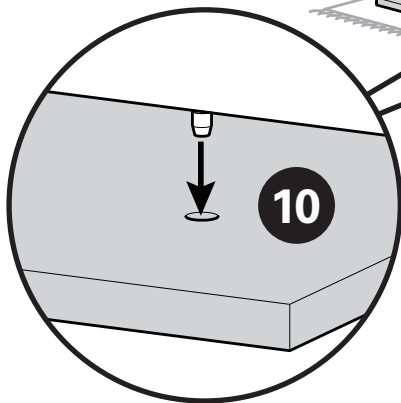
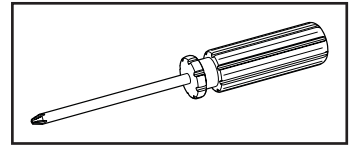

Step 6

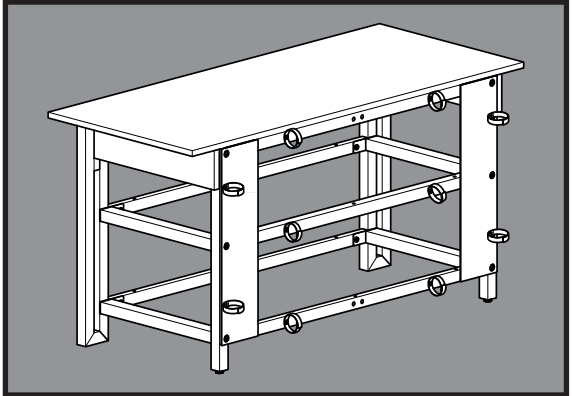
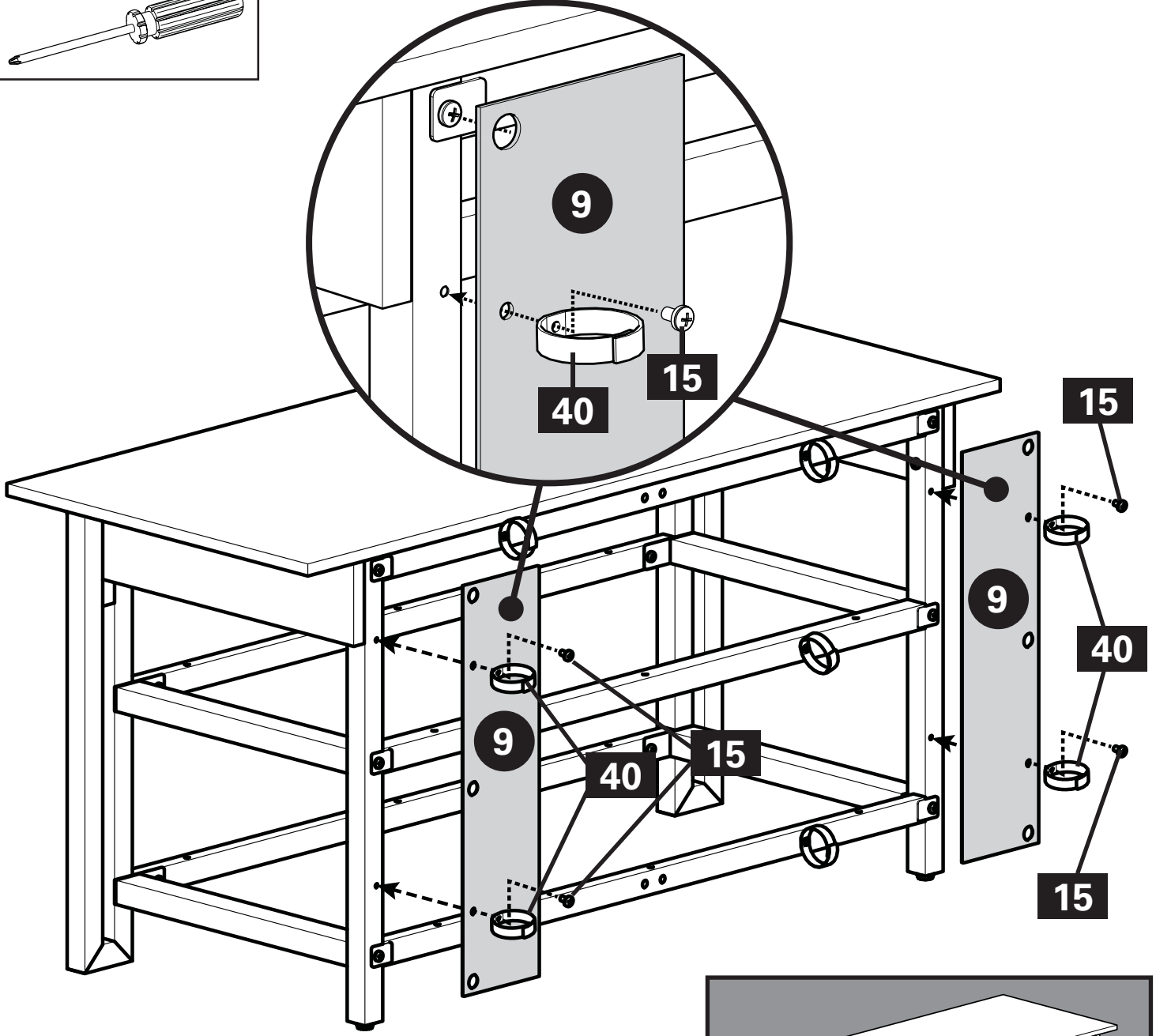
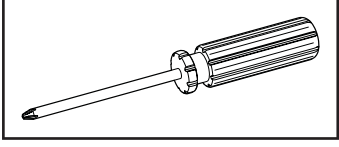
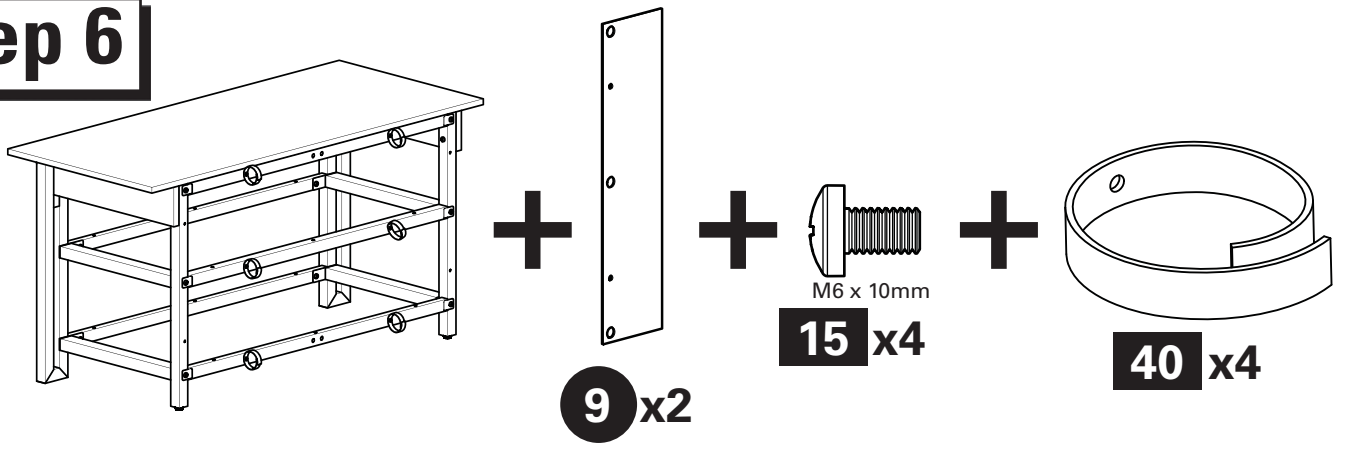

Step 7

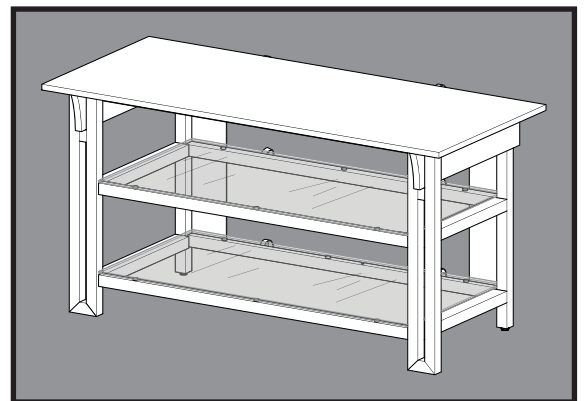
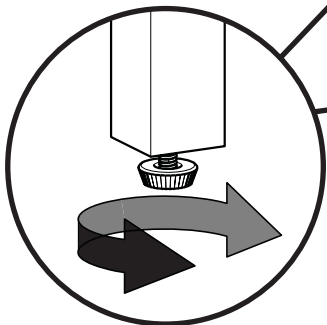
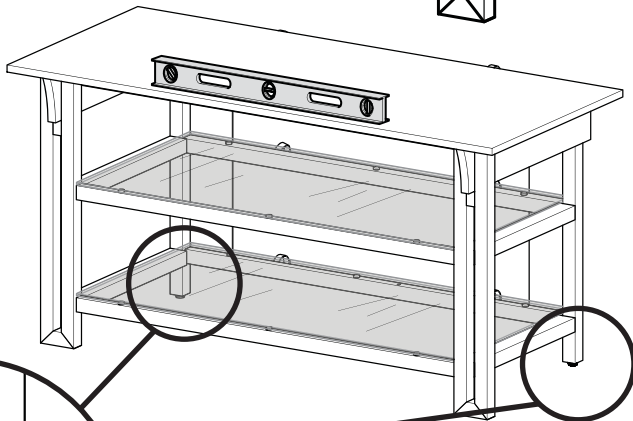
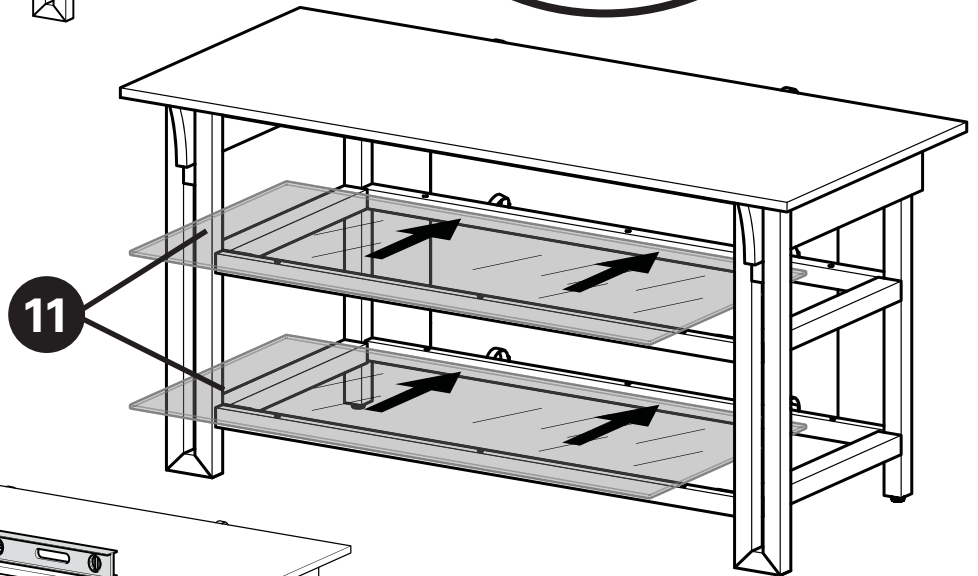
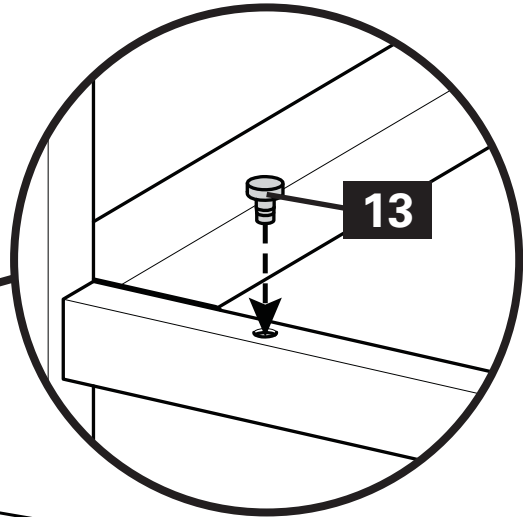
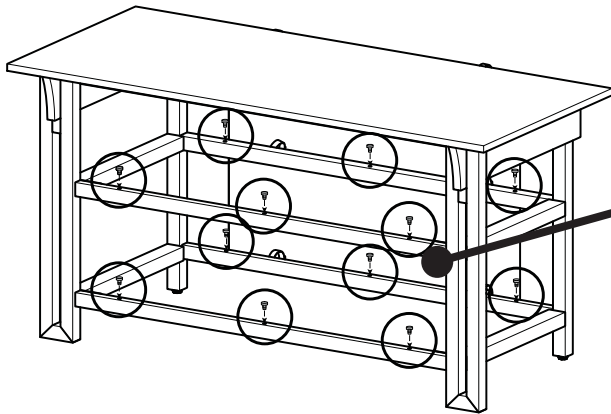
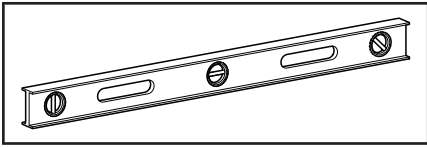
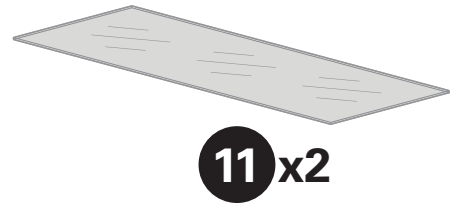
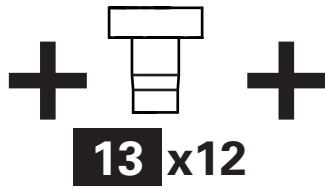
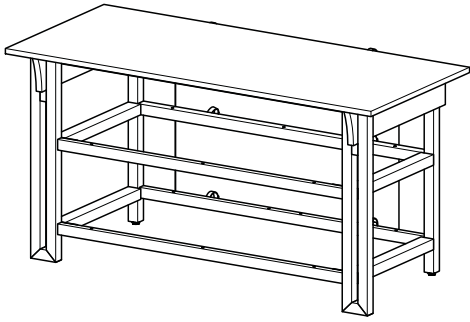

Step 8

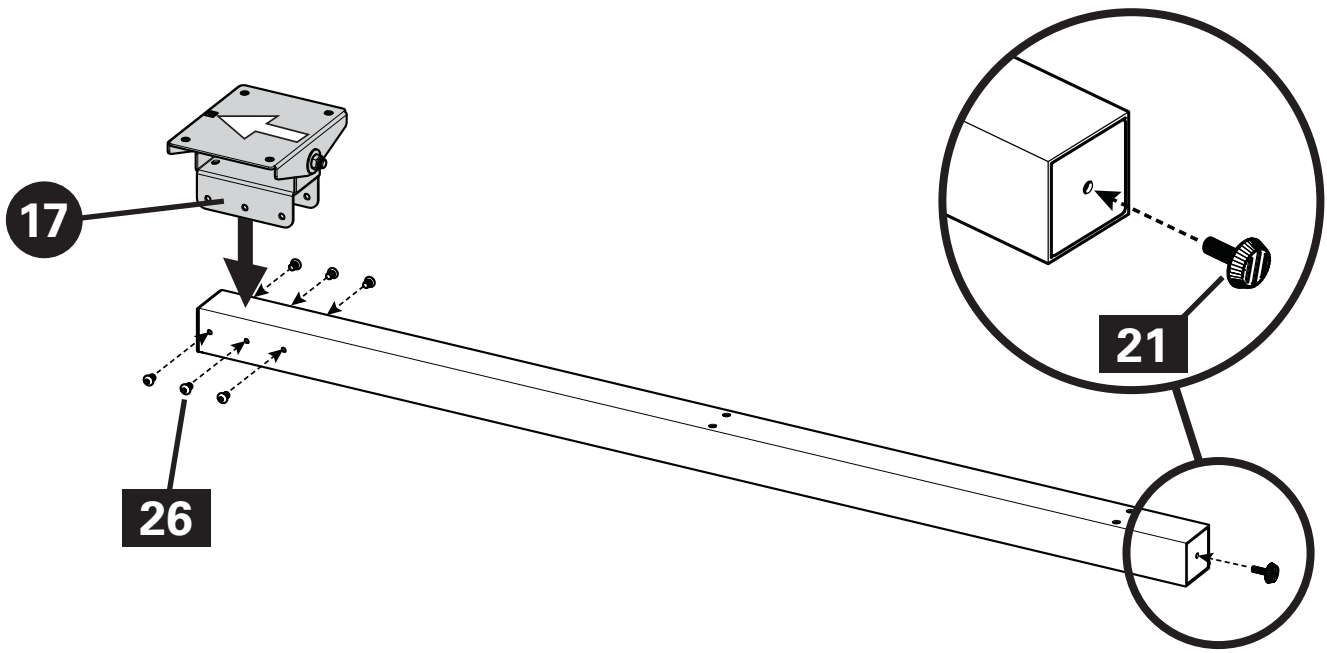
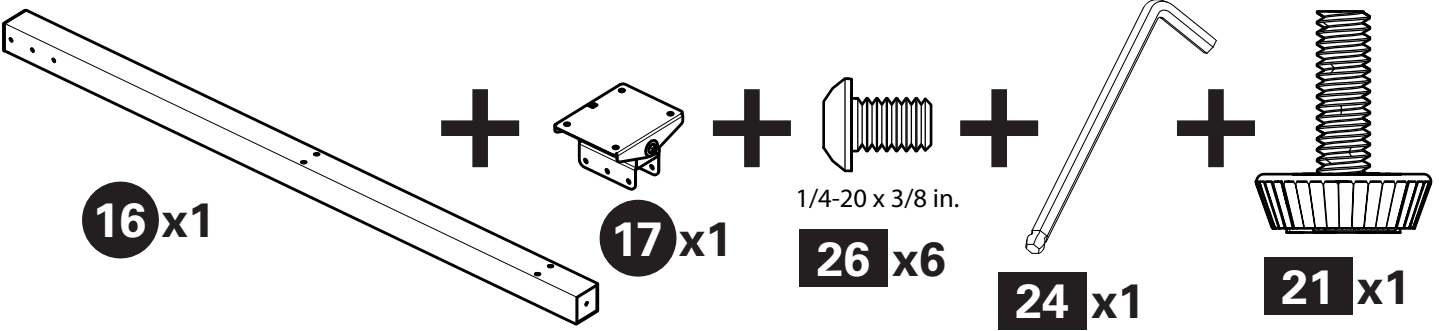

Step 9

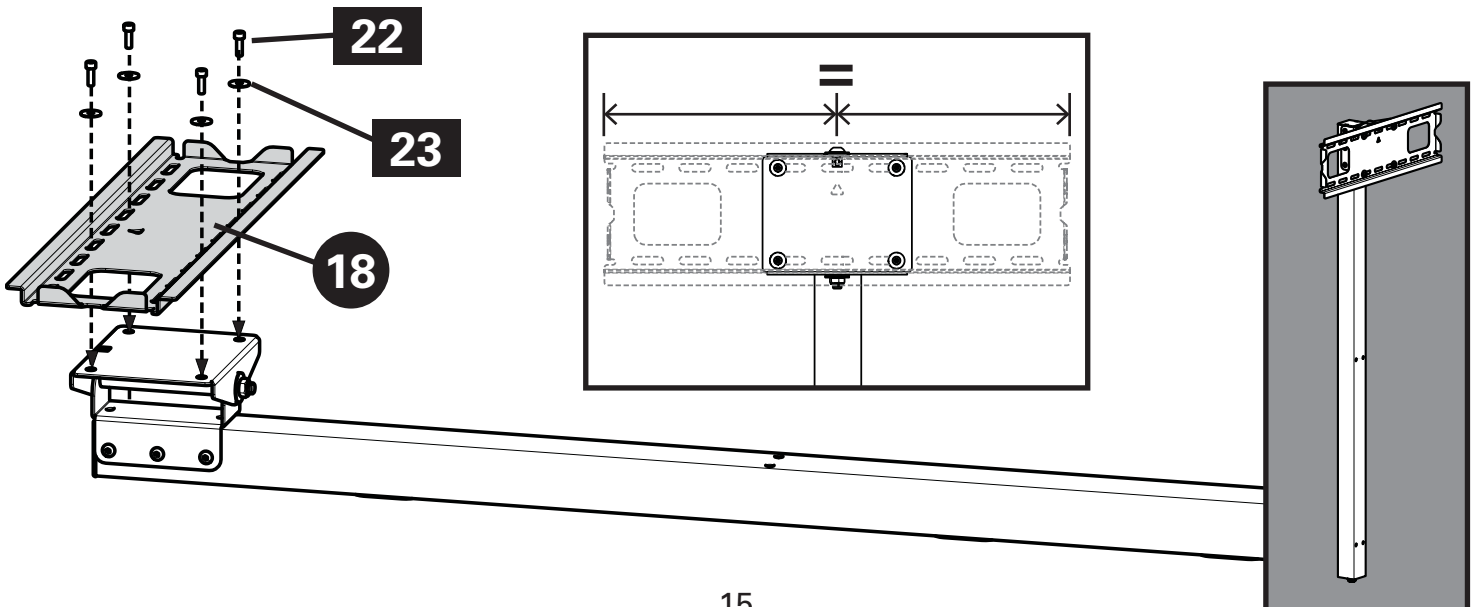
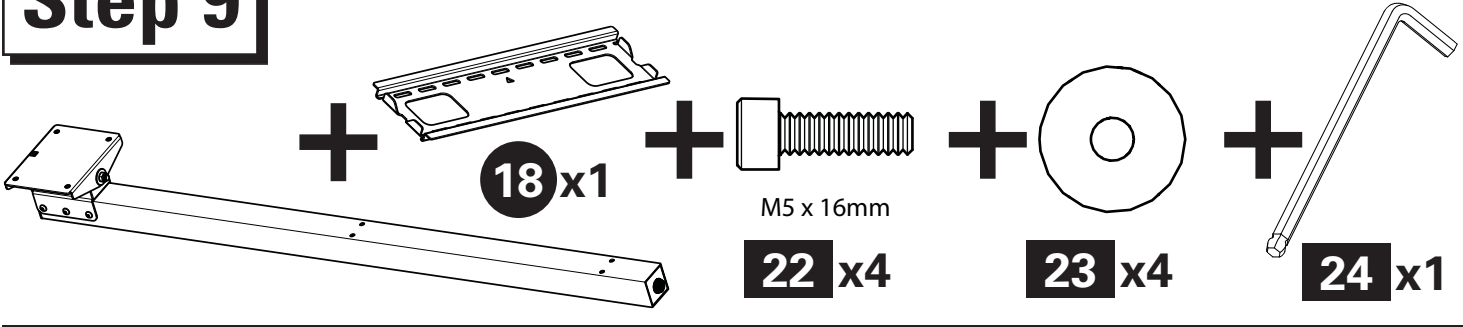

Step 10

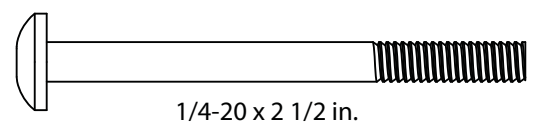
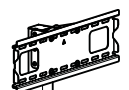
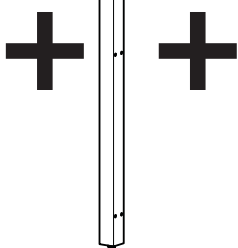
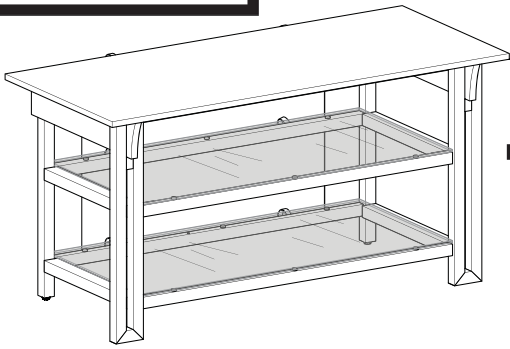

1/4-20 x 2 1/2 in.

28 x4

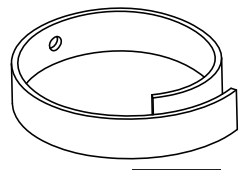

40 x2



M4 x 5mm

25 x2

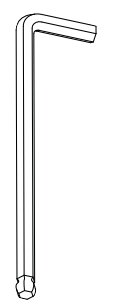

24 x1

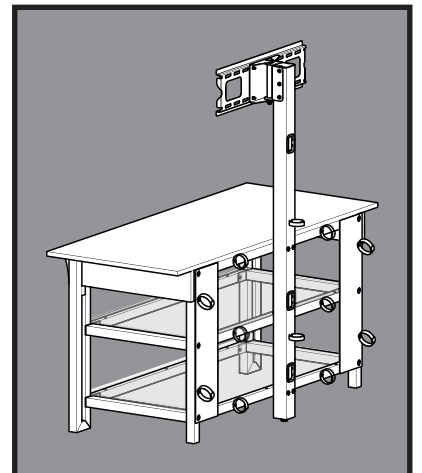
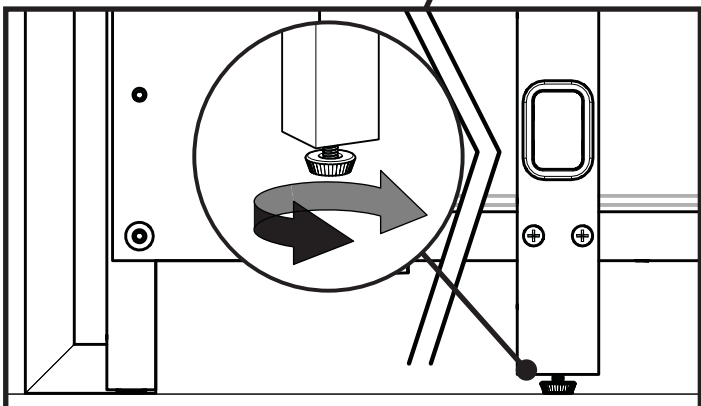
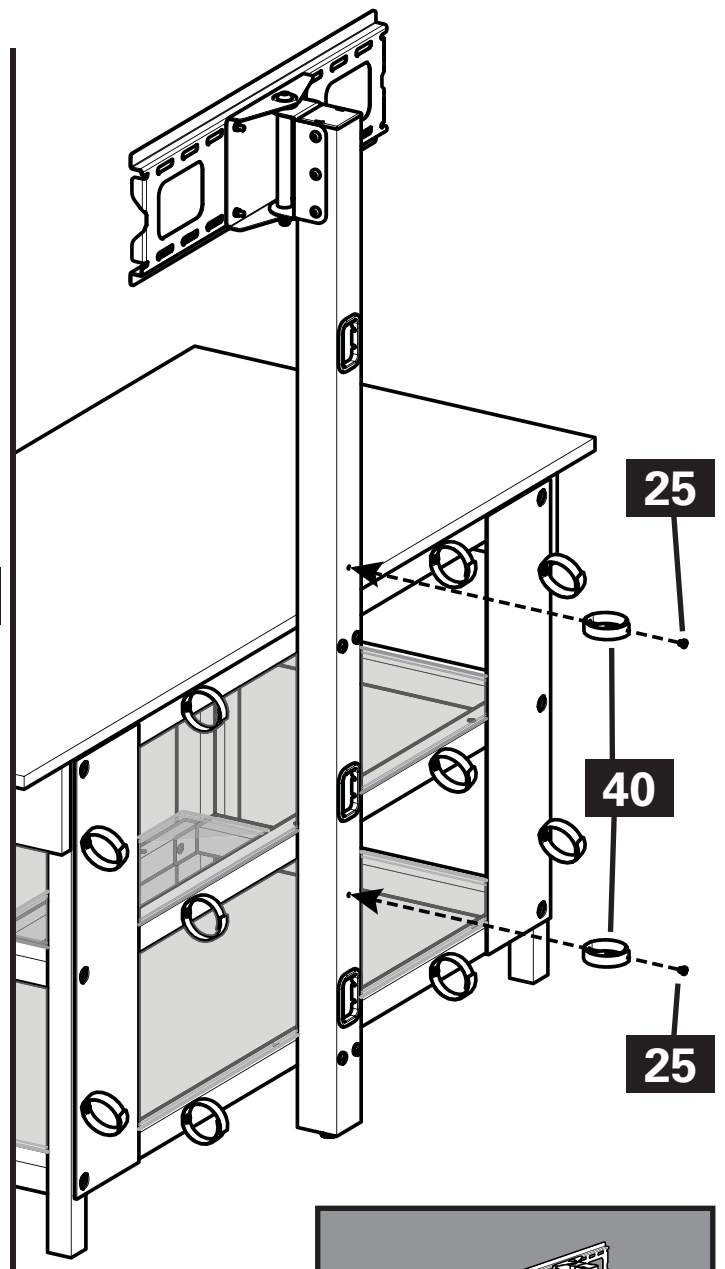
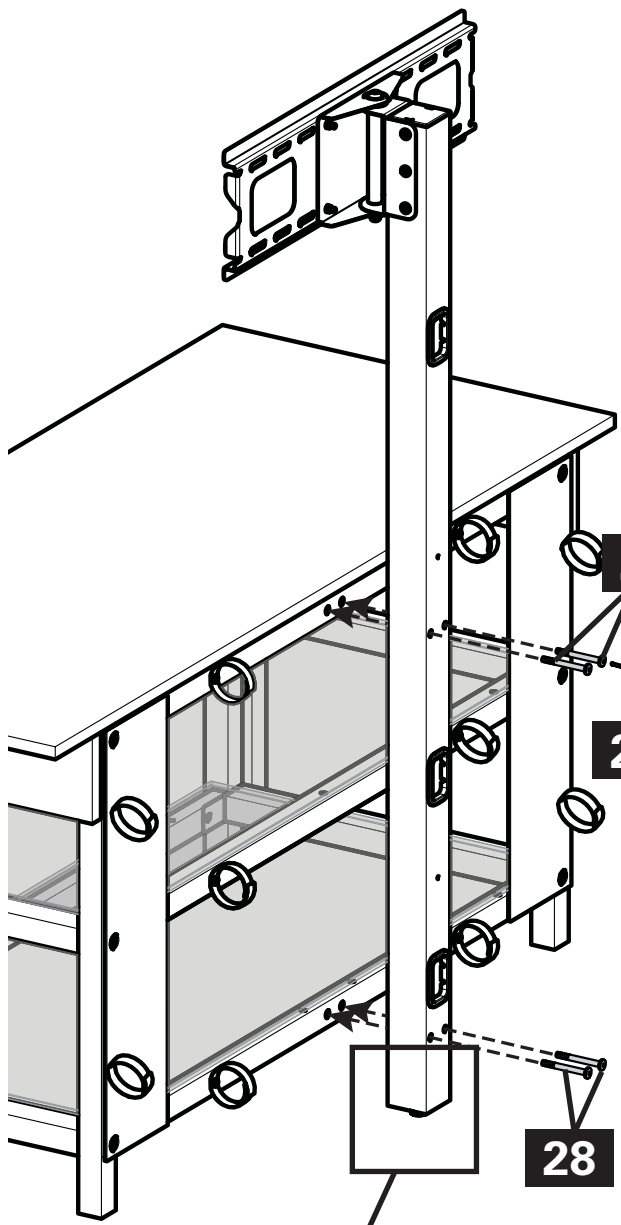

Select TV Hardware

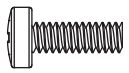

M4 x 12mm

29 x4



M4 x 35mm

30 x4

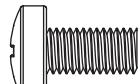

M6 x 12mm

31 x4

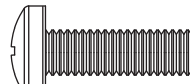

M6 x 20mm

32 x4

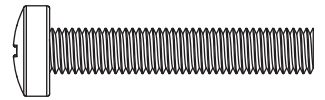

M6 x 35mm

33 x4

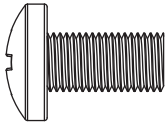

M8 x 16mm

34 x4

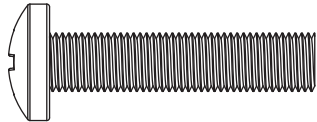

M8 x 35mm

35 x4

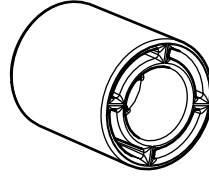

36 x4

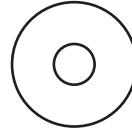

M4

37 x4

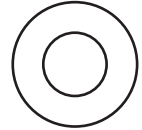

M6/M8

38 x4

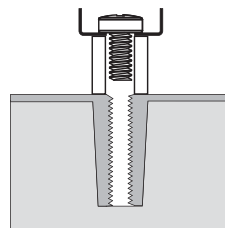
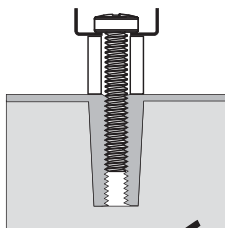
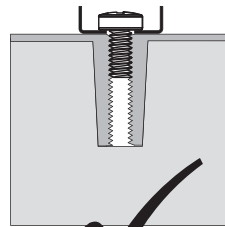
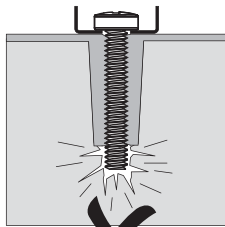
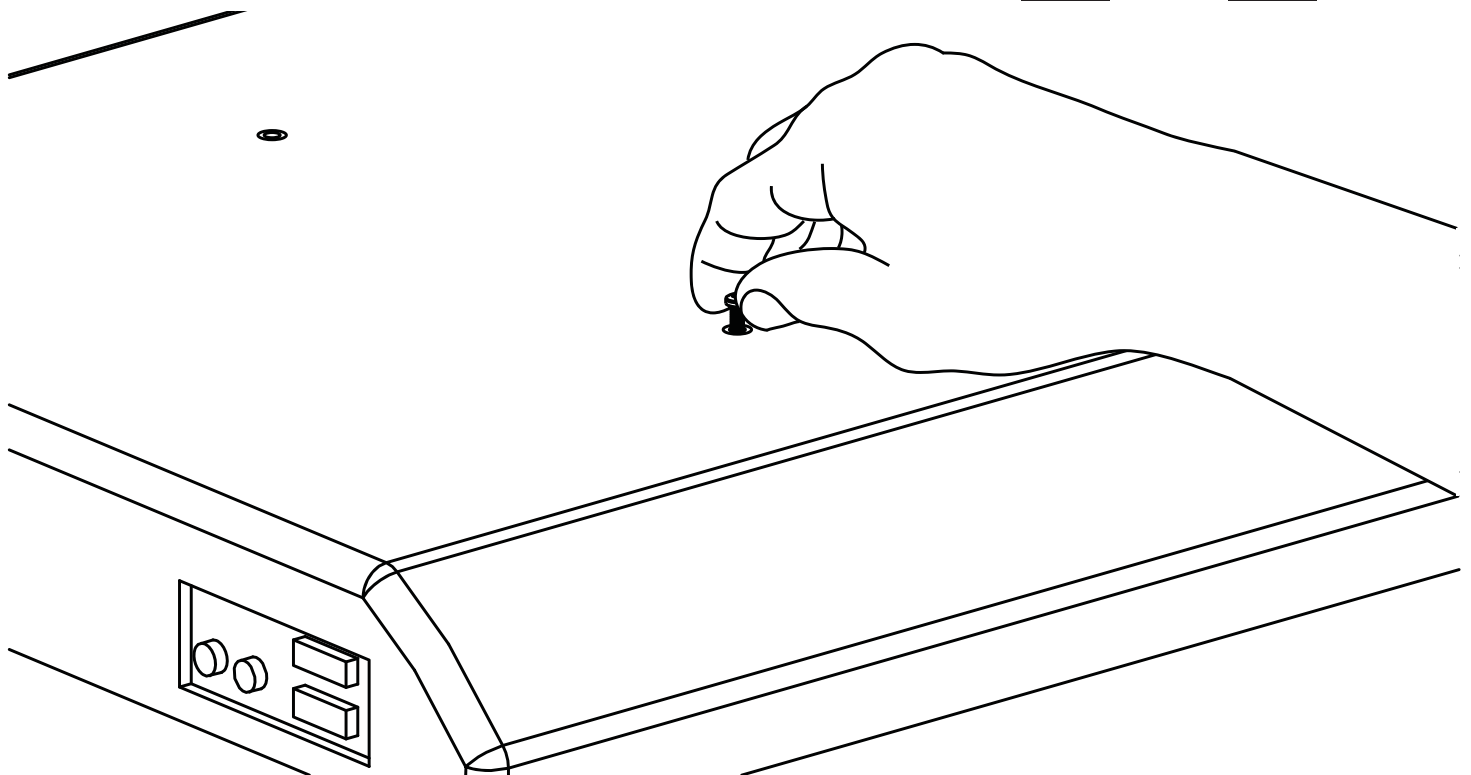

Step 11

**OPT
1**

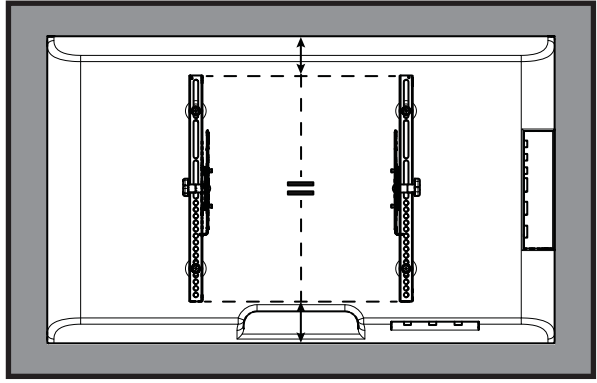
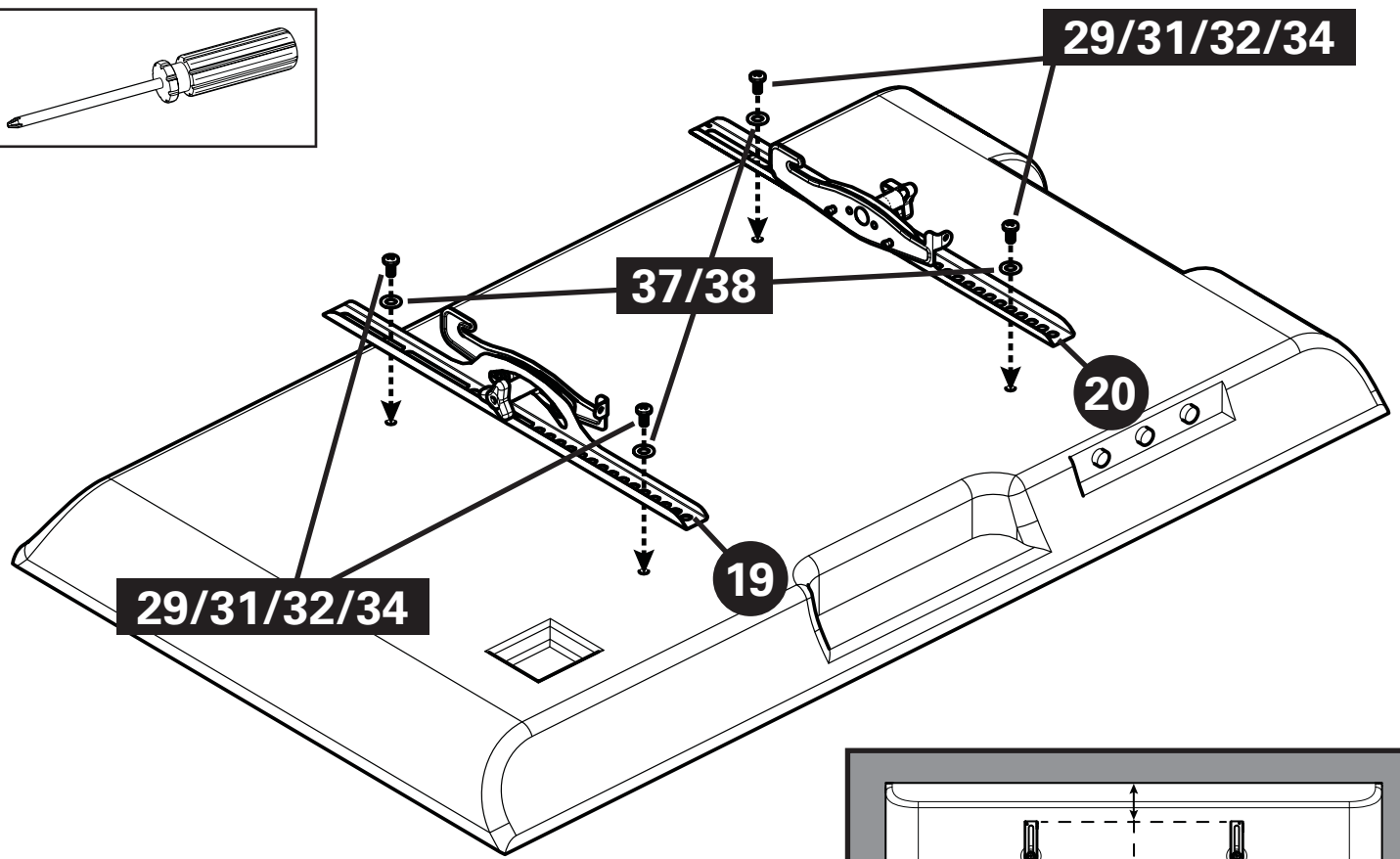
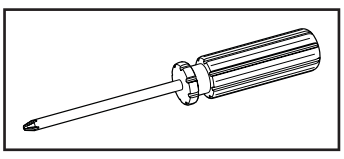
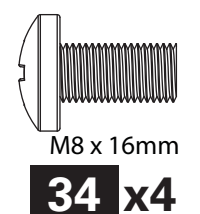
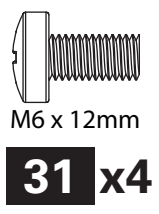
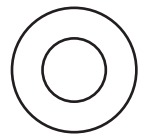
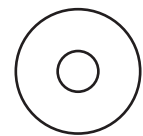
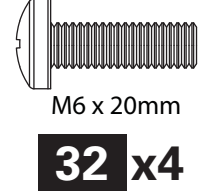
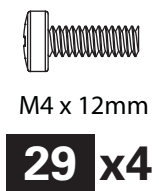
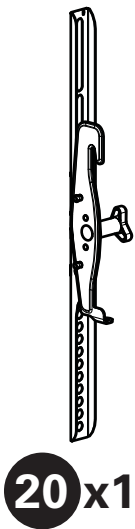
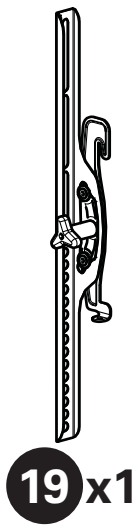
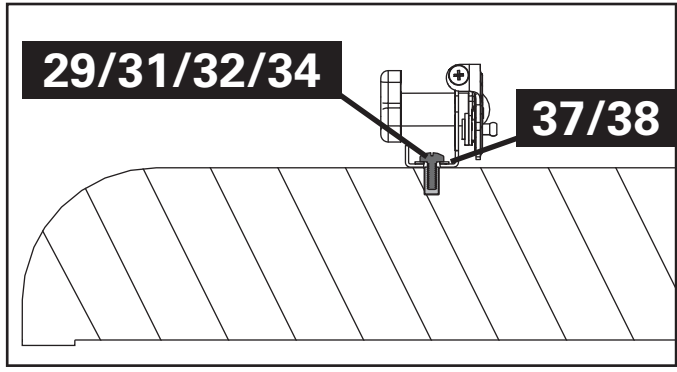
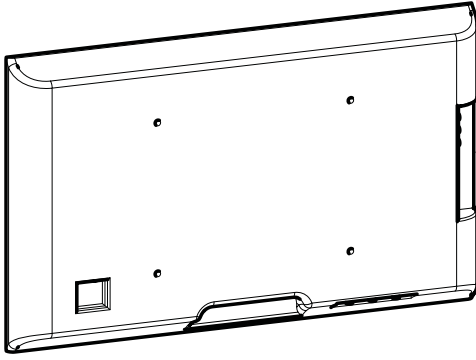

Step 11

**OPT
2**

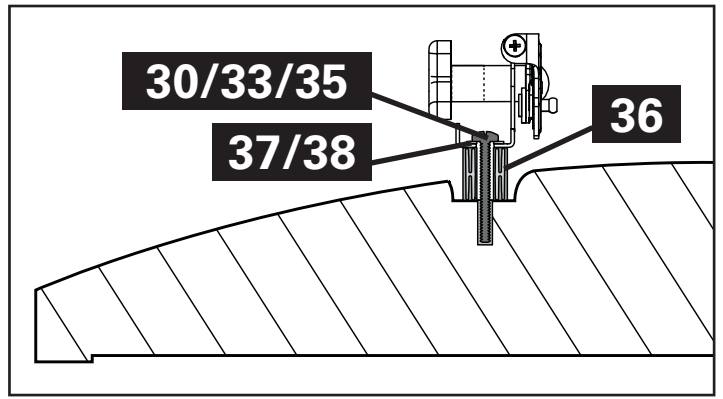
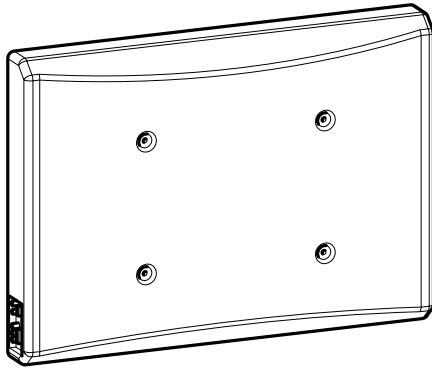

19 x1



20 x1

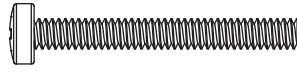

30 x4

M4 x 35mm

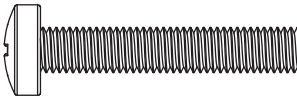

33 x4

M6 x 35mm

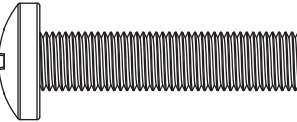

35 x4

M8 x 35mm

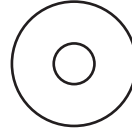

M4

37 x4

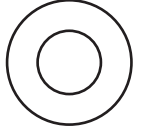

M6/M8

38 x4

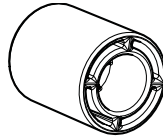

36 x4

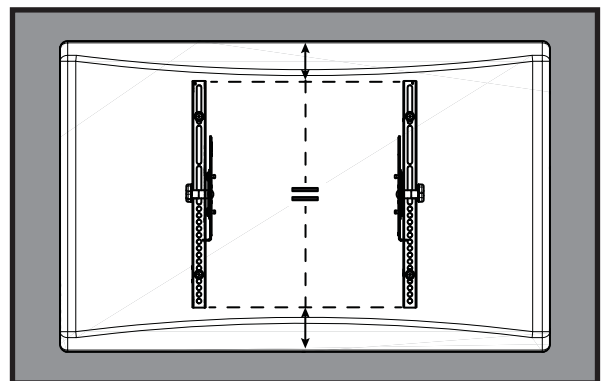
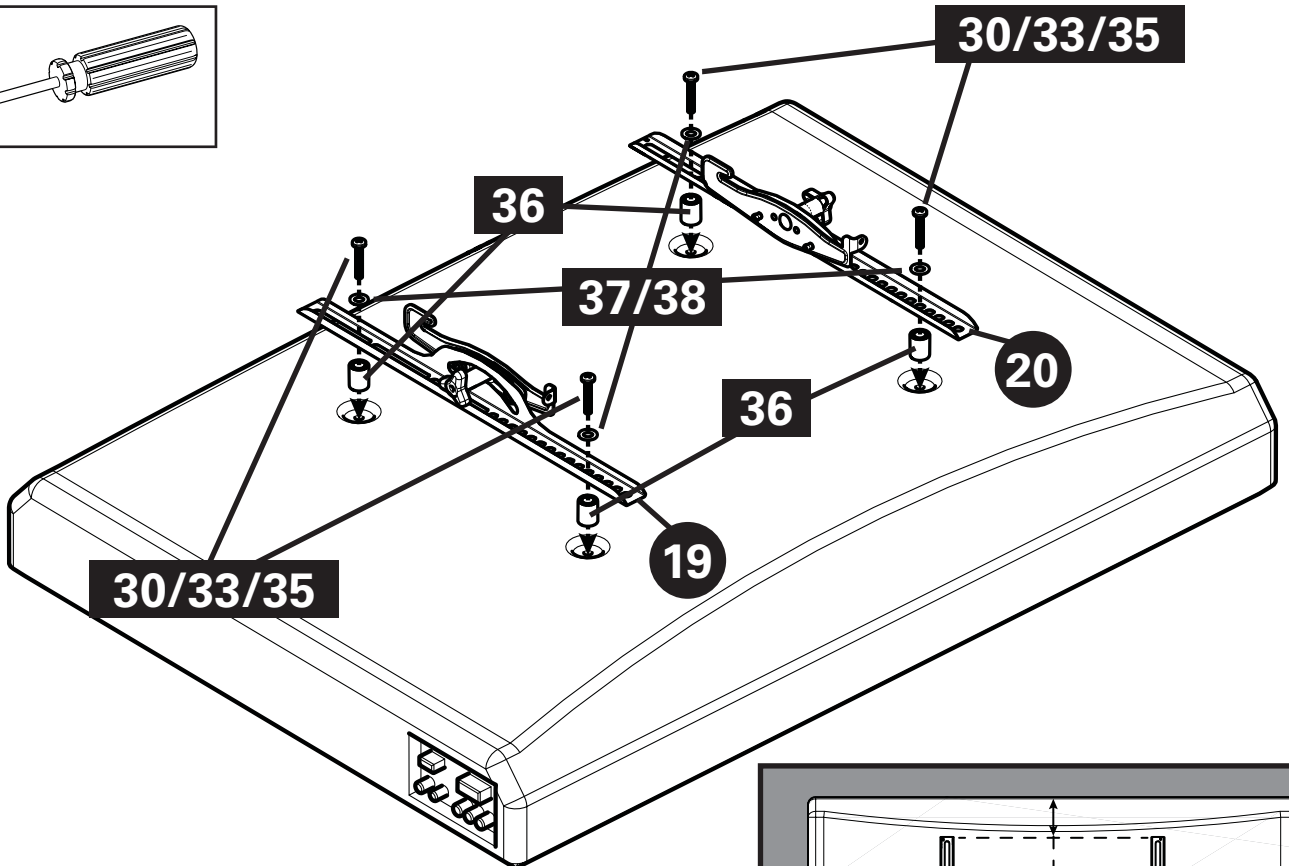
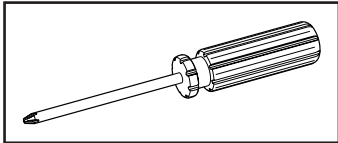

Step 12

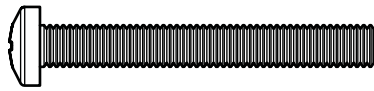

M5 x 40mm

27 x2

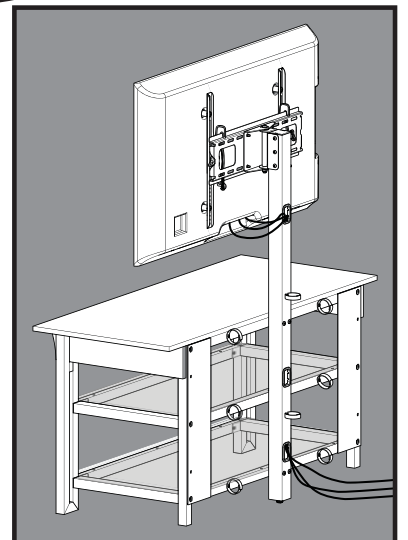
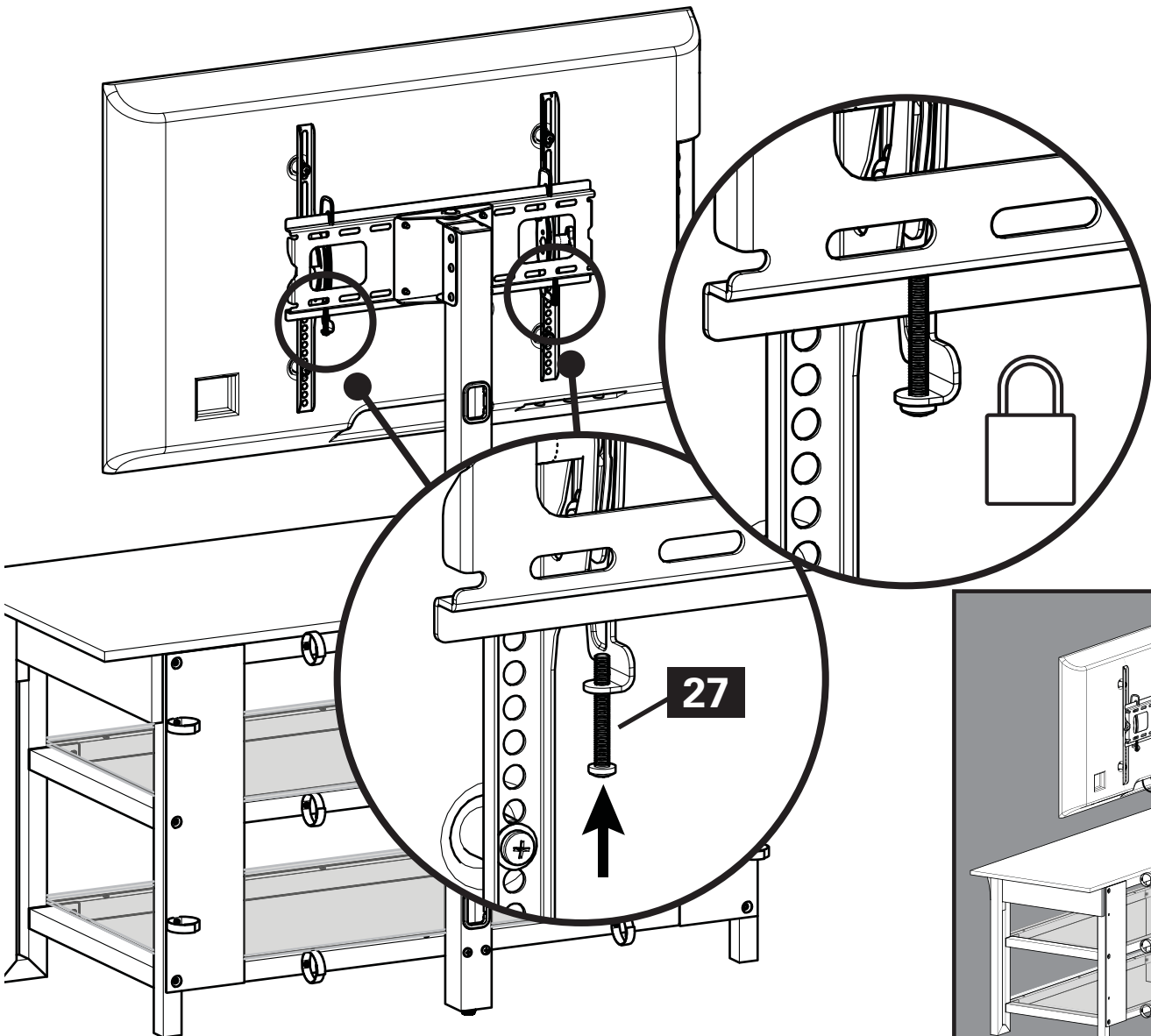
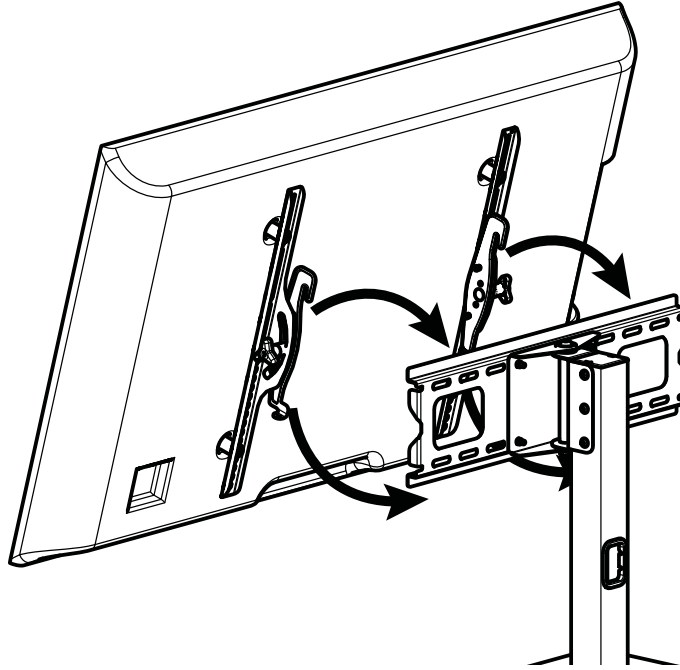
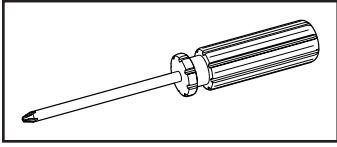

Wood Stud Wall Mounting **OPT**

▲ CAUTION: Improper use could reduce the holding power of the lag bolt. To avoid potential injuries or property damage:

- ✦ Pilot holes **MUST** be drilled to a depth of 75 mm (3 in.), using a 5.5 mm (7/32 in.) diameter drill bit.
- ✦ **DO NOT** over-tighten the lag bolts **42**.
- ✦ Any material covering the wall must not exceed 16 mm (5/8 in.).
- ✦ Minimum wood stud size: common 2 x 4 in. (nominal 1½ x 3½ in.).

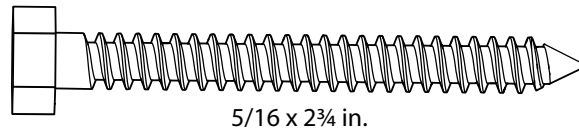
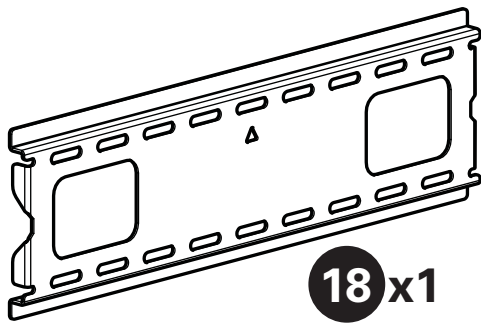

42 x4

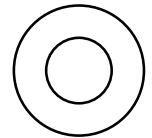

43 x4

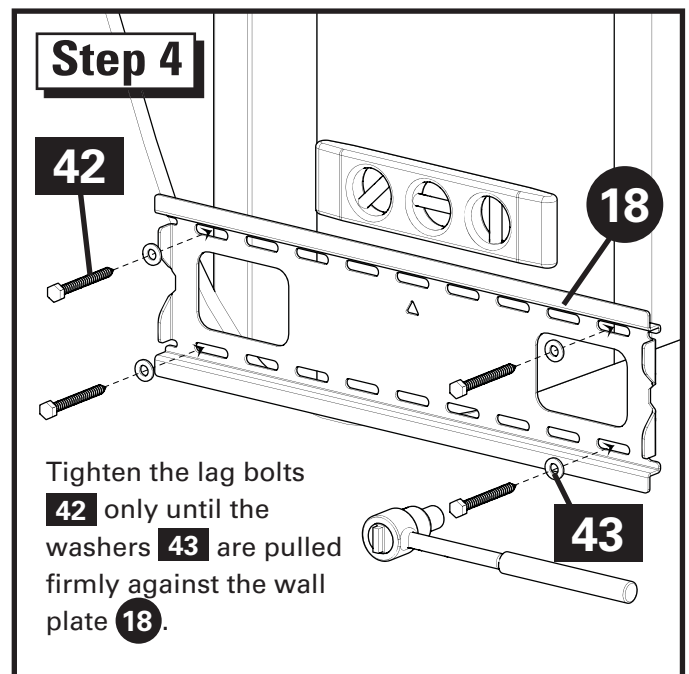
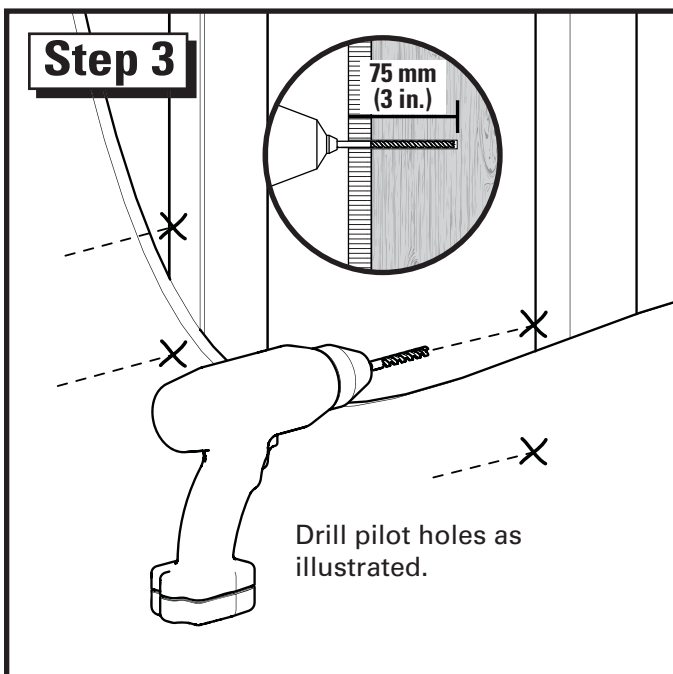
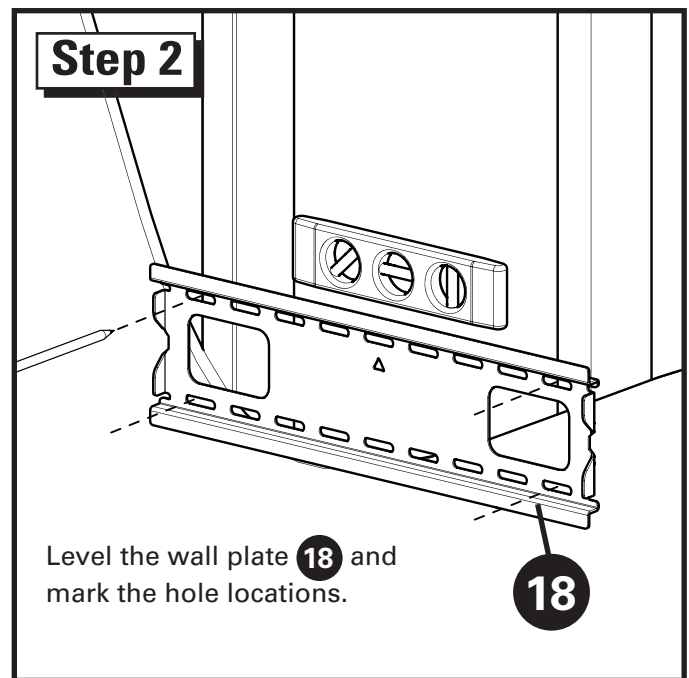
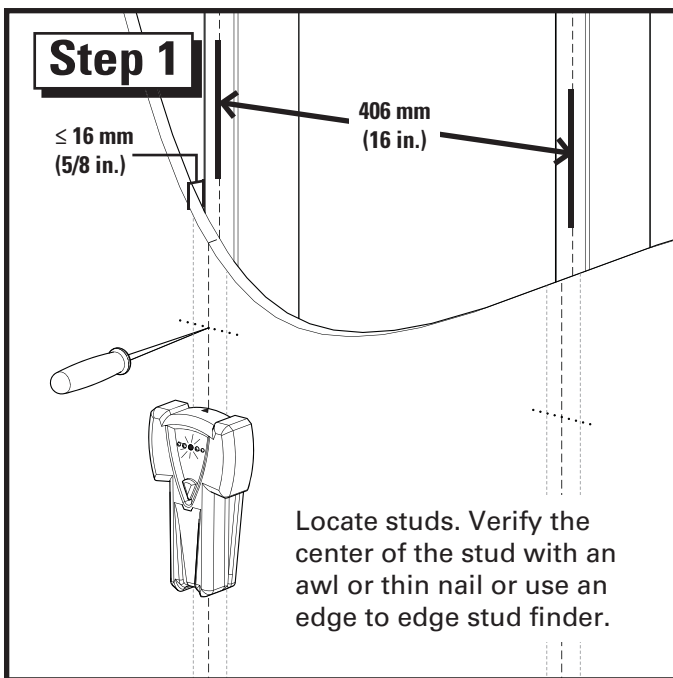

Solid Concrete and Concrete Block Wall Mounting



▲ CAUTION: Improper use could reduce the holding power of the lag bolt. To avoid potential injuries or property damage:

- ✗ Pilot holes **MUST** be drilled to a depth of 75 mm (3 in.), using a 10 mm (3/8 in.) diameter drill bit.
- ✗ Be sure the anchors **44** seat flush with the concrete surface.
- ✗ Mount wall plate directly onto the concrete surface.
- ✗ Never drill into the mortar between blocks.
- ✗ **DO NOT** over-tighten the lag bolts **42**.
- ✗ Minimum solid concrete thickness: 8 in.
- ✗ Minimum concrete block size: 8 x 8 x 16 in.
- ✗ Minimum horizontal space between fasteners: 406 mm (16 in.)

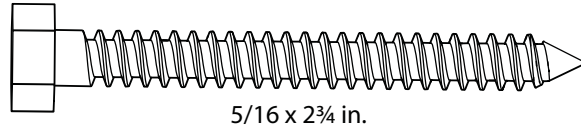
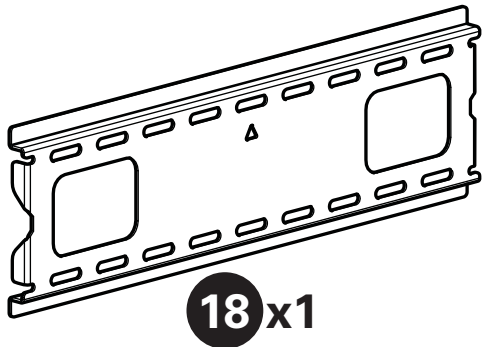

42 x4

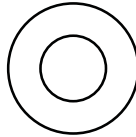

43 x4



44 x4

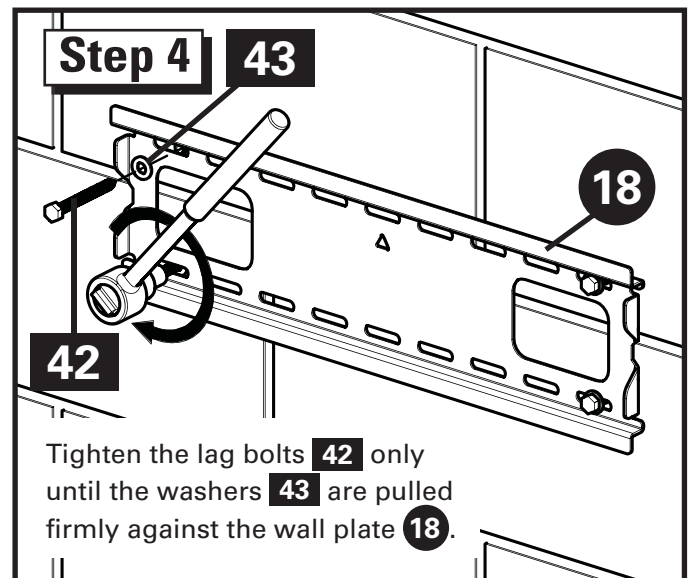
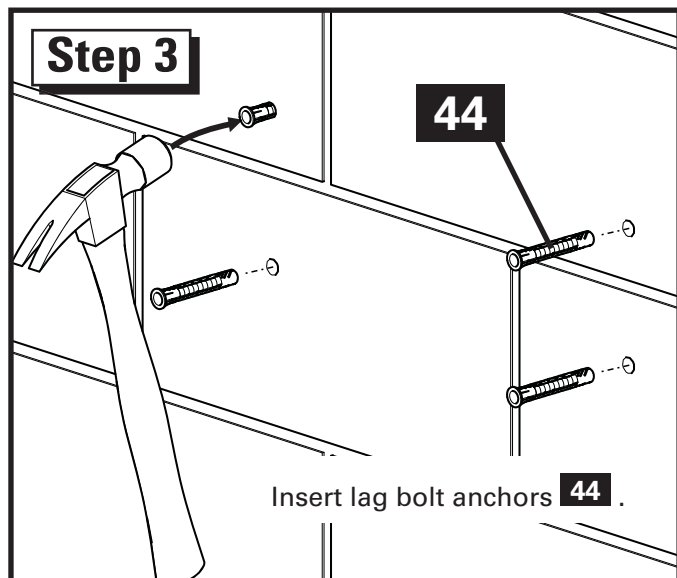
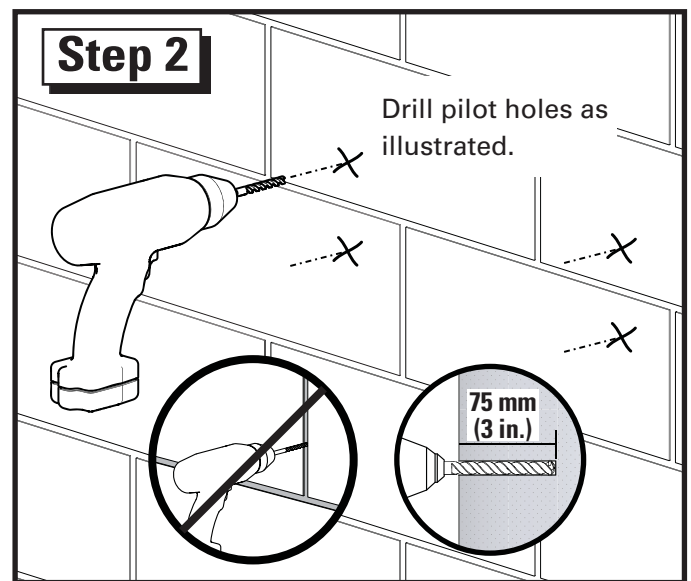
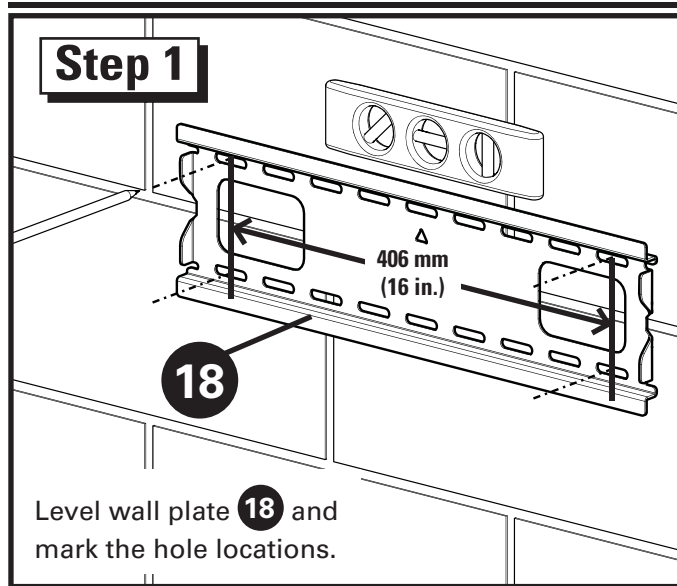

Hang the TV with Mounting Brackets onto the Wall Plate

OPT

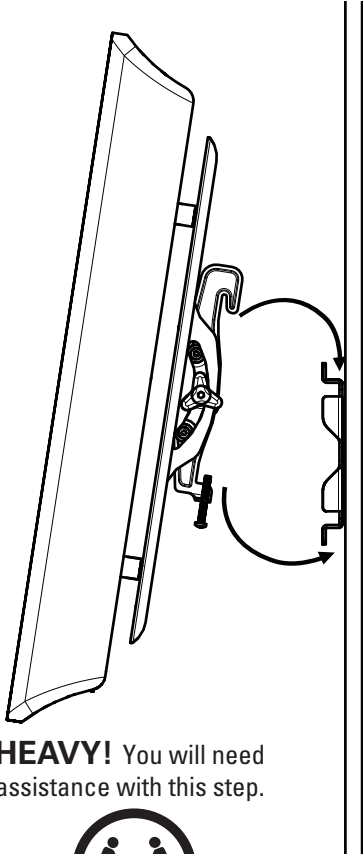

HEAVY! You will need assistance with this step.

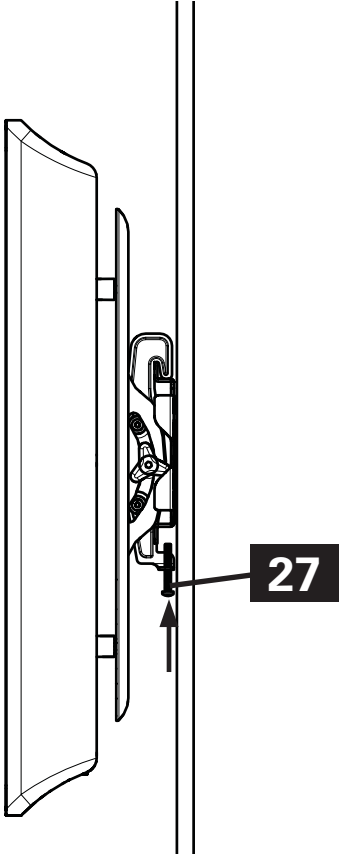

27

OPT

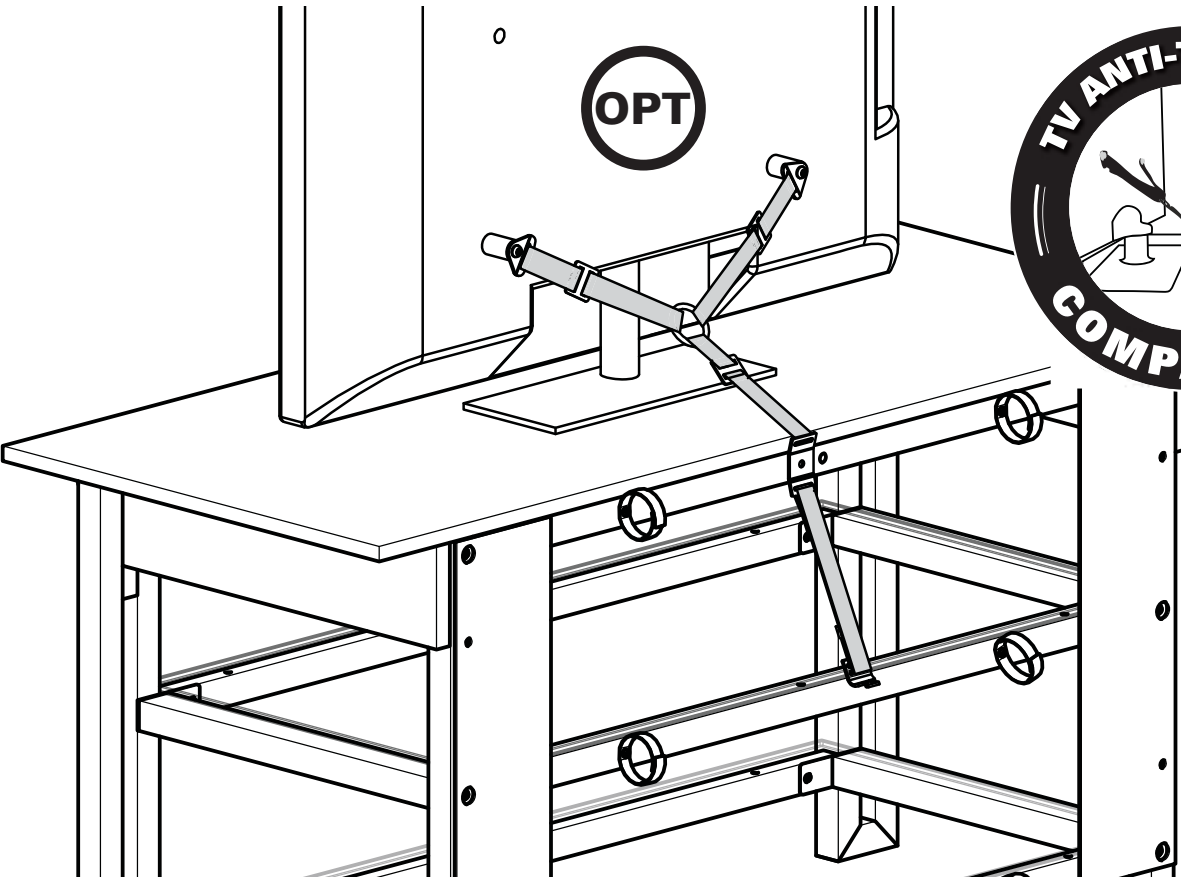

**INSTRUCCIONES IMPORTANTES DE SEGURIDAD. GUARDE ESTAS INSTRUCCIONES.
LEA TODO EL MANUAL ANTES DE UTILIZAR ESTE PRODUCTO.**

Antes de comenzar - Ver página 2

▲ PRECAUCIÓN: Evite posibles lesiones y daños materiales.

- No utilice este producto para ningún otro propósito que no sea el explícitamente especificado por el fabricante.
- Si no entiende las instrucciones o si tiene dudas acerca de la seguridad de la instalación, el montaje o el uso del producto, póngase en contacto con el servicio de atención al cliente de Sanus Systems o llame a un técnico cualificado.
- El fabricante no se responsabiliza de ningún daño o lesión resultante del montaje incorrecto o el uso indebido.

Peso Máximo - Ver página 2

PRECAUCIÓN / INSTRUCCIONES DE CUIDADO - Ver página 2

▲ PRECAUCIÓN: Evite posibles lesiones o daños materiales! - Ver página 4

Hemos elegido vidrio templado para este producto por sus características de resistencia y seguridad. De todas formas, el vidrio templado debe ser manejado con cuidado para evitar posibles daños al producto o lesiones físicas.

- El manejo inadecuado durante el traslado, el armado o el uso puede derivar en daños que debiliten el vidrio templado.
- Revise periódicamente el vidrio para verificar que no tenga astillas, rajaduras, o rayones profundos.
- Si encuentra astillas, rajaduras, o rayones profundos, deje de usar el producto y comuníquese con atención al cliente.

INSTRUCCIONES DE CUIDADO

Para lograr un acabado natural, quite el polvo con regularidad usando un paño seco. Cuando sea necesario, pase un paño húmedo, no mojado, y seque con otro paño.

▲ PRECAUCIÓN: Este producto fue diseñado para su uso con televisores de pantalla plana **ÚNICAMENTE**.

Para evitar que la unidad se caiga, asegúrese de colocar su televisor de pantalla plana (no de tubo) en el centro del mueble.

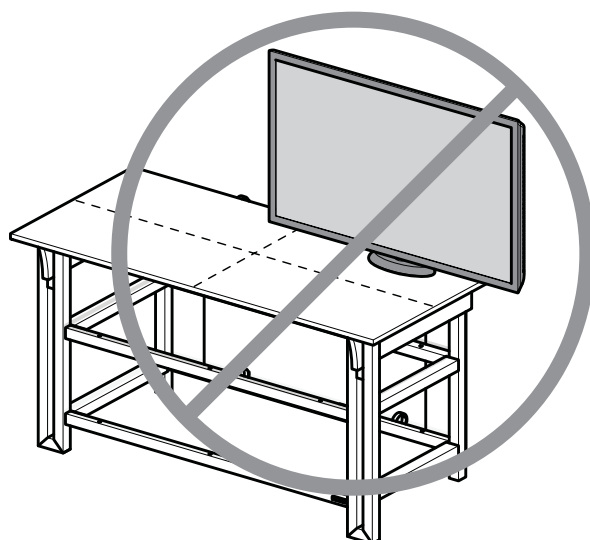
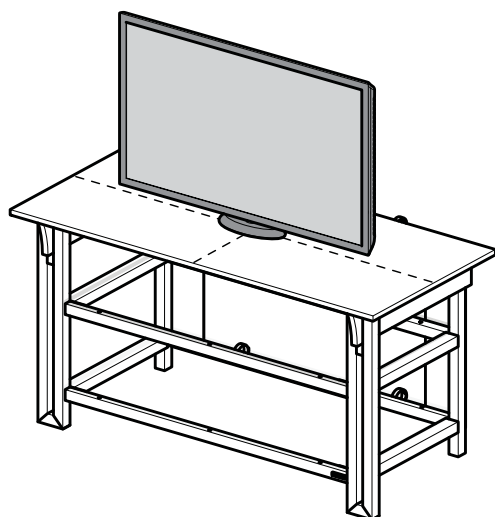

Herramientas necesarias - Ver página 3

Piezas y elementos de montaje suministrados - Ver página 3

▲ ADVERTENCIA: Este producto contiene piezas pequeñas que podrían causar asfixia si se tragasen.

Antes de comenzar a montar la unidad, verifique que todas las piezas estén incluidas y en buen estado. En caso de que falten piezas o alguna esté dañada, no devuelva el elemento defectuoso al distribuidor. Póngase en contacto con el servicio de atención al cliente. Nunca utilice piezas en mal estado.

MONTAJE SOBRE PARED

Herramientas necesarias - Ver página 7

Piezas y elementos de montaje suministrados - Ver página 7

MONTAJE SOBRE PARED

Montaje sobre montantes de madera - Ver página 21

▲ PRECAUCIÓN: El uso indebido podría reducir la capacidad de retención de los tornillos. Para evitar lesiones y daños materiales:

- ✘ Los orificios DEBEN realizarse con una broca de 75 mm (3 pulgadas) de diámetro hasta una profundidad de 5.5 mm (7/32 pulgadas).
- ✘ No ajuste en exceso los tornillos [42].
- ✘ El material que recubre la pared no debe exceder los 16 mm (5/8 pulgada).

1. Localice los montantes. Verifique el centro del montante con un punzón o un clavo delgado, o bien utilice un detector de bordes de montantes.
 - ✘ Nivele la placa mural [18] y marque la ubicación de los orificios.
2. Realice los orificios como se indica en la ilustración.
 - ✘ Ajuste los tornillos [42] solamente hasta que las arandelas [43] queden firmes contra la placa mural [18].

Montaje sobre concreto macizo o sobre bloques de hormigón

- Ver página 22

▲ PRECAUCIÓN: El uso indebido podría reducir la capacidad de retención de los tornillos. Para evitar lesiones y daños materiales:

- ✘ Los orificios DEBEN realizarse con una broca de 75 mm (3 pulgadas) de diámetro hasta una profundidad de 10 mm (3/8 pulgadas).
- ✘ Cerciórese de que los anclajes [44] queden nivelados respecto de la superficie de hormigón.
- ✘ Instale la placa mural directamente sobre la superficie de hormigón.
- ✘ Nunca perfora el cemento que une los bloques.
- ✘ No ajuste en exceso los tornillos [42].

1. Nivele la placa mural y marque [18] la ubicación de los orificios.
2. Realice los orificios como se indica en la ilustración.
3. Inserte los anclajes [44].
4. Ajuste los tornillos [42] solamente hasta que las arandelas [43] queden firmes contra la placa mural [18].

Cuelgue el televisor con las placas de sujeción adosadas, en la placa mural - Ver página 23

¡PESADO! Necesitará ayuda para realizar esta operación.

Avant de commencer - Voir à la page 2

▲ ATTENTION : Évitez les dommages matériels et les blessures!

- Ne pas utiliser ce produit à d'autres fins que celles spécifiées par le fabricant.
- Si vous ne comprenez pas toutes ces instructions ou si vous avez des doutes sur la sécurité de l'installation, du montage ou de l'utilisation de ce produit, veuillez contacter un installateur qualifié ou le service à la clientèle.
- Le fabricant n'est pas responsable des blessures ou des dommages causés par une mauvaise utilisation ou un montage incorrect.

Capacité de charge - Voir à la page 2

ATTENTION / INSTRUCTIONS D'ENTRETIEN - Voir à la page 2

▲ ATTENTION : Évitez tout dommage matériel ou blessure! - Voir à la page 4

Le verre trempé est choisi pour ce produit en raison de sa solidité et de ses caractéristiques de sécurité. Il faut cependant manipuler le verre trempé avec soin afin d'éviter des dommages matériels ou des blessures.

- Une mauvaise manipulation pendant l'expédition, l'assemblage ou l'utilisation peut endommager le verre trempé et causer son affaiblissement.
- Vérifier périodiquement si le verre est ébréché, fissuré ou égratigné en profondeur.
- Si le verre est ébréché, fissuré ou égratigné en profondeur, cessez de l'utiliser et contactez le service à la clientèle.

INSTRUCTIONS D'ENTRETIEN - Voir à la page 4

Pour le bois naturel, enlever la poussière régulièrement à l'aide d'un chiffon doux et sec. Au besoin, essuyer avec un linge humide et non mouillé, puis sécher.

▲ ATTENTION : Ce produit est conçu pour être utilisé **SEULEMENT** avec des téléviseurs à écran plat.

Pour éviter de faire basculer le meuble, assurez-vous de bien centrer votre téléviseur à écran plat (pas d'écran cathodique) sur le dessus de votre meuble.

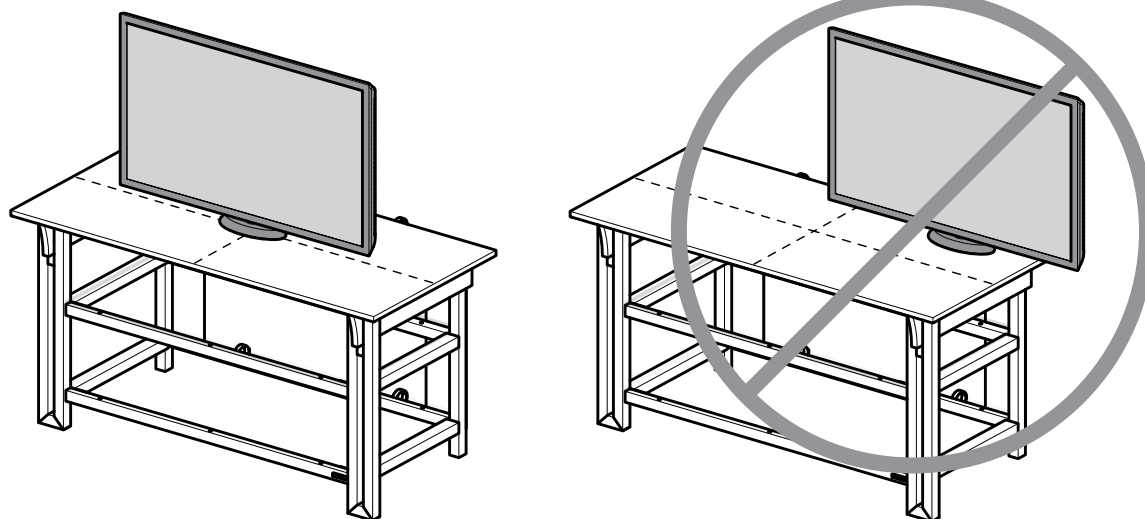

Outils nécessaires - Voir à la page 2

Pièces et matériel fournis - Voir à la page 3

▲ AVERTISSEMENT : Ce produit contient de petites pièces qui peuvent représenter un risque d'étouffement.

Avant de commencer l'assemblage, assurez-vous que toutes les pièces sont présentes et qu'elles ne sont pas endommagées. Si une pièce est manquante ou endommagée, ne retournez pas les pièces endommagées à votre revendeur. Contactez plutôt le service clientèle. N'utilisez jamais de pièces endommagées!

MONTAGE MURAL

Outils nécessaires - Voir à la page 7

Pièces et matériel fournis - Voir à la page 7

MONTAGE MURAL

Installation sur des murs avec montants de bois - Voir à la page 21

▲ **ATTENTION** : Une utilisation inadéquate peut réduire la force de rétention du boulon tire-fond. Afin d'éviter tout dommage matériel ou blessure :

- ✘ Les avant-trous DOIVENT être percés à une profondeur de 75 mm (3 po) à l'aide d'un foret de 5,5 mm (7/32 po).
 - ✘ Ne pas trop serrer les boulons tire-fond [42].
 - ✘ Tout matériau de revêtement de mur ne doit pas excéder 16 mm (5/8 in.).
1. Trouvez les montants. Vérifiez le centre du montant à l'aide d'un poinçon ou d'un clou fin ou utilisez un détecteur de montant bord à bord.
 2. Mettez la plaque murale [18] à niveau et marquez l'emplacement des trous.
 3. Percez des avant-trous tel qu'illustré.
 4. Serrez les boulons tire-fond [42] jusqu'à ce que les rondelles [43] s'appuient fermement sur la plaque murale [18].

Montage sur béton coulé ou sur blocs de béton - Voir à la page 22

▲ **ATTENTION** : Une utilisation inadéquate peut réduire la force de rétention du boulon tire-fond. Afin d'éviter tout dommage matériel ou blessure :

- ✘ Les avant-trous DOIVENT être percés à une profondeur de 75 mm (3 po) à l'aide d'un foret de 10 mm (3/8 po).
5. Assurez-vous que les douilles à expansion [44] ne dépassent pas de la surface de béton.
 - ✘ Montez la plaque murale directement sur la surface de béton.
 - ✘ Ne jamais percer dans le mortier entre les blocs.
 6. Ne pas trop serrer les boulons tire-fond [42].
1. Mettez la plaque murale à niveau et marquez les emplacements des trous.
 2. Percez des avant-trous tel qu'illustré.
 3. Insérez d'abord les douilles à expansion des boulons tire-fond [44].
 4. Serrez les boulons tire-fond [42] jusqu'à ce que les rondelles [43] s'appuient fermement sur la plaque murale [18].

Suspendre le téléviseur avec les supports de montage sur la plaque murale - Voir à la page 23

TRÈS LOURD ! Cette étape requiert deux personnes.

©2013 Milestone AV Technologies, a Duchossois Group Company. All rights reserved. Sanus is a division of Milestone. All other brand names or marks are used for identification purposes and are trademarks of their respective owners.

Milestone AV Technologies and its affiliated corporations and subsidiaries (collectively, "Milestone"), intend to make this manual accurate and complete. However, Milestone makes no claim that the information contained herein covers all details, conditions, or variations. Nor does it provide for every possible contingency in connection with the installation or use of this product. The information contained in this document is subject to change without notice or obligation of any kind. Milestone makes no representation of warranty, expressed or implied, regarding the information contained herein. Milestone assumes no responsibility for accuracy, completeness or sufficiency of the information contained in this document.

SANUS • 6436 City West Parkway • Eden Prairie, MN 55344 USA