

# SANUS

## LMF115 INSTRUCTION MANUAL

Para Español ver página 18

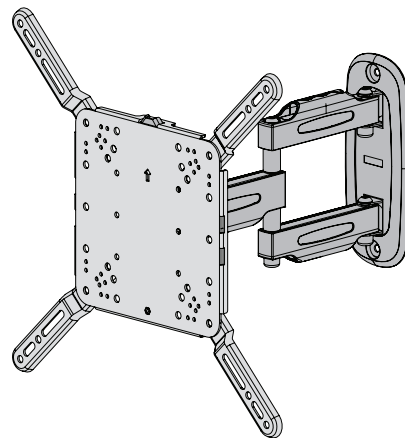

## WE'RE HERE TO HELP



Want to watch a video that shows how easy this DIY project will be?



Watch it now at:  
[SANUS.com/2848](https://www.sanus.com/2848)

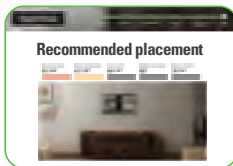

Get it right the first time. HeightFinder™ shows you where to drill.



Check it out at:  
[SANUS.com/2850](https://www.sanus.com/2850)



Our US-based install experts are standing by to help.



Call us at:  
**1-855-734-7805**

# IMPORTANT SAFETY INSTRUCTIONS – SAVE THESE INSTRUCTIONS – PLEASE READ ENTIRE MANUAL PRIOR TO USE

Before getting started, let's make sure this mount is perfect for you!

**1** Does your TV (including accessories) weigh *more* than 50 lb (22.6 kg)?



**No** – Perfect!

**Yes** – This mount is NOT compatible. Visit [MountFinder.sanus.com](http://MountFinder.sanus.com) or call 1-855-734-7805 to find a compatible mount.

**2** What is your wall made of?

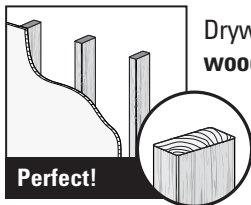

Drywall with wood studs?

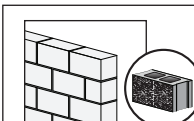

Solid concrete or concrete block?



Unsure?

Call Customer Service: 1-855-734-7805

**3** Do you have all the tools needed?



Tape Measure



Pencil

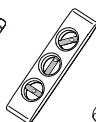

Level



Screwdriver



Electric Drill



1/2 in. (13 mm) Socket Wrench

Wood Stud Install



Stud Finder



Awl



7/32 in. (5.5 mm) Wood Drill Bit

Concrete Install



Hammer



3/8 in. (10 mm) Concrete Drill Bit

**4** Ready to begin?

Please read through these instructions completely to be sure you're comfortable with this easy install process. Also check your TV owner's manual to see if there are any special requirements for mounting your TV.

If you do not understand these instructions or have doubts about the safety of the installation, assembly or use of this product, contact Customer Service at 1-855-734-7805.

**CAUTION:** Avoid potential personal injury or property damage!

- This product is designed for use in wood stud, solid concrete, and concrete block walls - DO NOT install into drywall alone
- This product is designed for INDOOR USE ONLY
- The wall must be capable of supporting five times the weight of the TV and mount combined
- Do not use this product for any purpose not explicitly specified by manufacturer
- Manufacturer is not responsible for damage or injury caused by incorrect assembly or use

# Dimensions

## TV INTERFACE

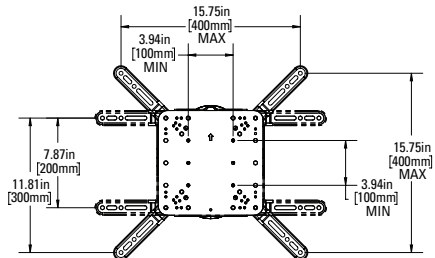

## 3-D

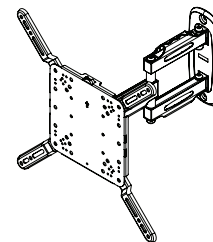

## WALL PLATE

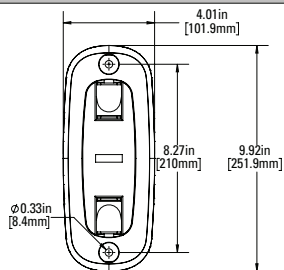

## TOP VIEW - EXTENDED

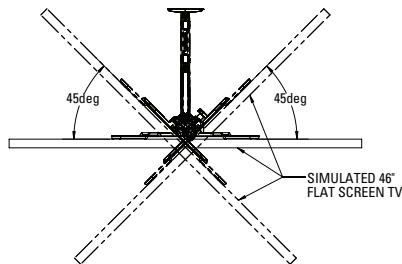

## SIDE VIEW - EXTENDED

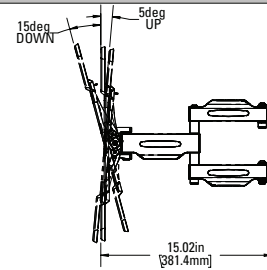

## FULLY ASSEMBLED MOUNT

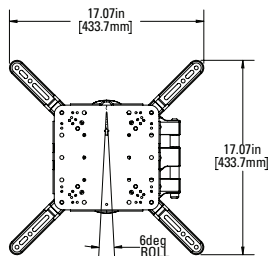

## TOP VIEW - RETRACTED

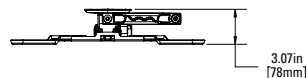

## SIDE VIEW RETRACTED

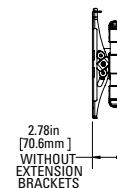

# Supplied Parts and Hardware

**⚠ WARNING:** This product contains small items that could be a choking hazard if swallowed. Before starting assembly, verify all parts are included and undamaged. If any parts are missing or damaged, do not return the damaged item to your dealer; contact Customer Service. Never use damaged parts!

**NOTE:** Not all hardware included will be used.

## STEP 1 Parts and Hardware

### 01 TV Screws

(qty. 4 each) [Only one size fits your TV]

M4

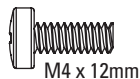

M4 x 12mm

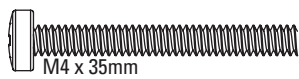

M4 x 35mm

M6

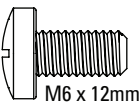

M6 x 12mm

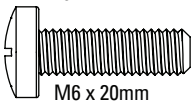

M6 x 20mm



M6 x 35mm

M8

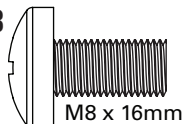

M8 x 16mm

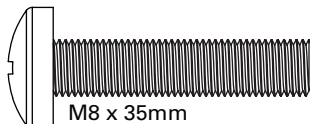

M8 x 35mm

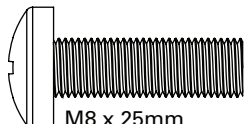

M8 x 25mm

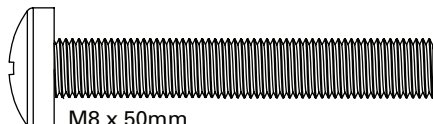

M8 x 50mm

### Washers

(qty. 4)

02

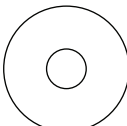

M4

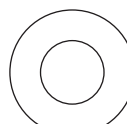

M6/M8

### Spacer

[If necessary]

(qty. 4)

03



M4/M6/M8

2.5 mm

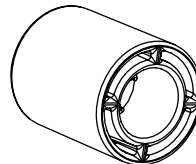

M4/M6/M8

22 mm

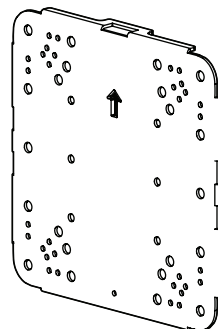

TV Bracket

(qty. 1)

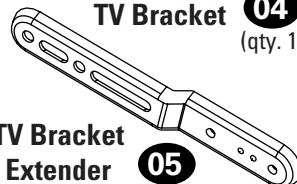

TV Bracket  
Extender

05

(qty. 4)

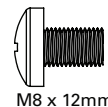

M8 x 12mm

TV Bracket

Screw (qty. 8)

## STEP 2 Parts and Hardware

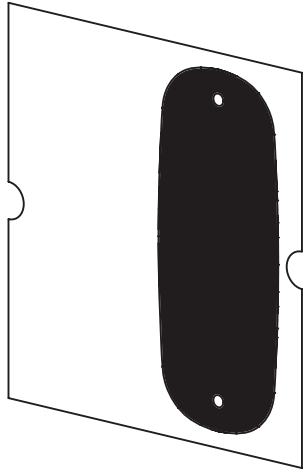

Wall Plate  
Template

**07** (qty. 1)

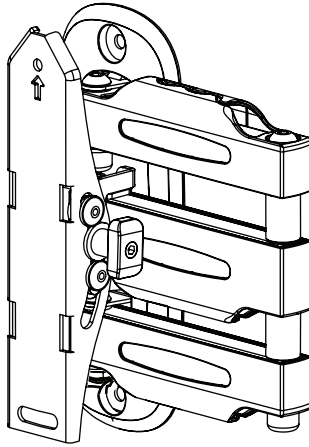

Arm Assembly

**08** (qty. 1)

## STEP 2B: Concrete Installation Kit CMK1 [NOT INCLUDED]

Contact Customer Service to inquire about the CMK1 Concrete Installation Kit.

### Concrete Anchor

**C1**  
(qty. 2)

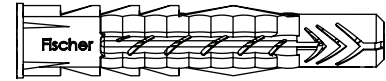

Fischer UX10 x 60R Anchor

### Lag Bolt

**09**  
(qty. 2)

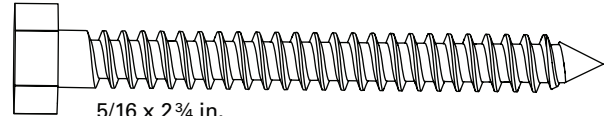

5/16 x 2 3/4 in.

## STEP 3 Parts and Hardware

### Nut Cap

**10**  
(qty. 1)



### Locking Screw

**11**  
(qty. 1)

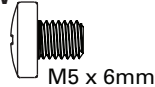

M5 x 6mm

### Washer

**12**  
(qty. 1)



# STEP 1 Attach TV bracket to TV

## 1.1 Measure Your TV Hole Pattern

Measure the width and height of your TV hole pattern in cm.

Record your measurements:

Width \_\_\_\_\_ cm x Height \_\_\_\_\_ cm

inches	cm	mm
3	7.5	75
4	10	100
7 7/8	20	200
11 3/4	30	300
15 3/4	40	400

inch dimensions are approximate

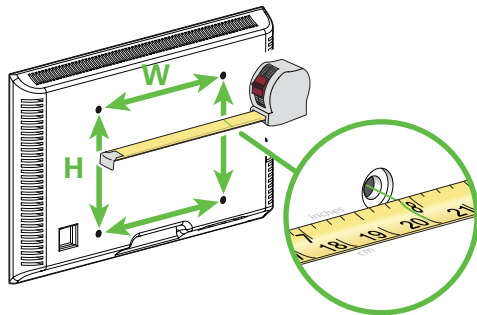

## 1.2 Assemble Your TV bracket

Based on your TV hole pattern measurements (**W cm x H cm**), determine your TV bracket configuration: A, B, C, D or E.

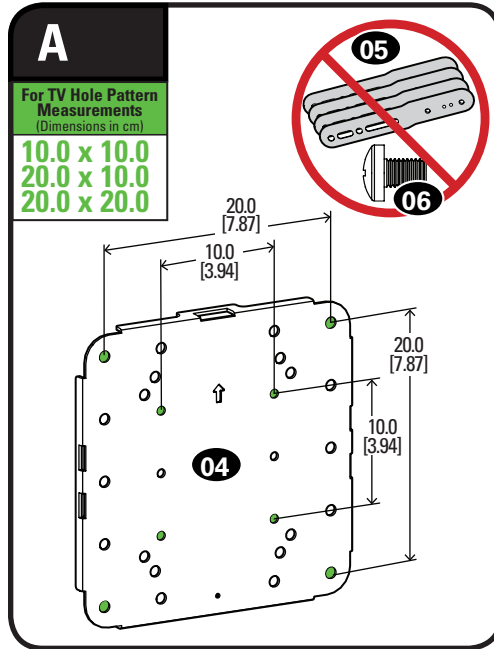

These smaller hole patterns only use TV bracket **04**. Do not use the four extenders **05** and eight screws **06**.

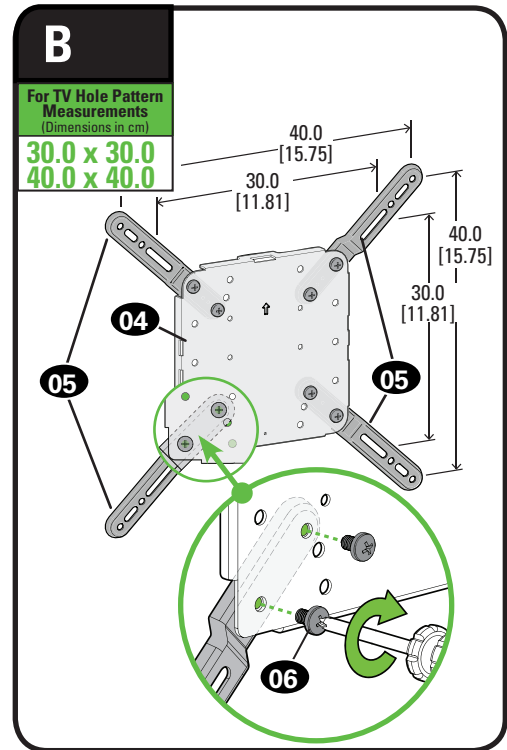

Assemble extenders **05** onto TV bracket **04** and secure using eight screws **06** in the corner holes indicated.

**C**

For TV Hole Pattern  
Measurements  
(Dimensions in cm)

**40.0 x 30.0**

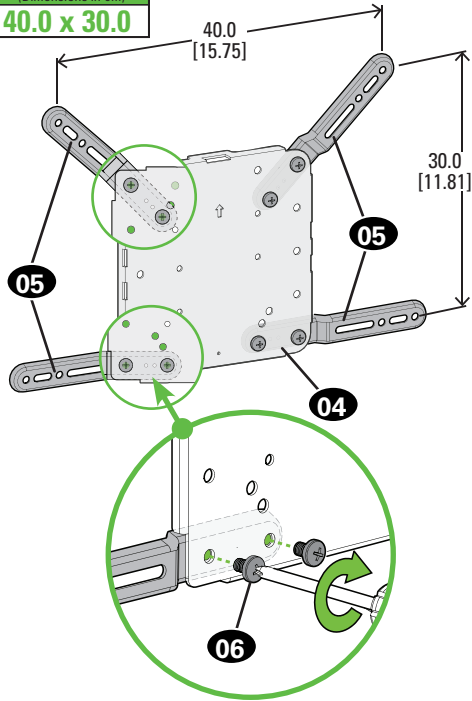

Assemble extenders **05** onto TV bracket **04** and secure using eight screws **06** in the corner holes indicated.

**D**

For TV Hole Pattern  
Measurements  
(Dimensions in cm)

**40.0 x 20.0**

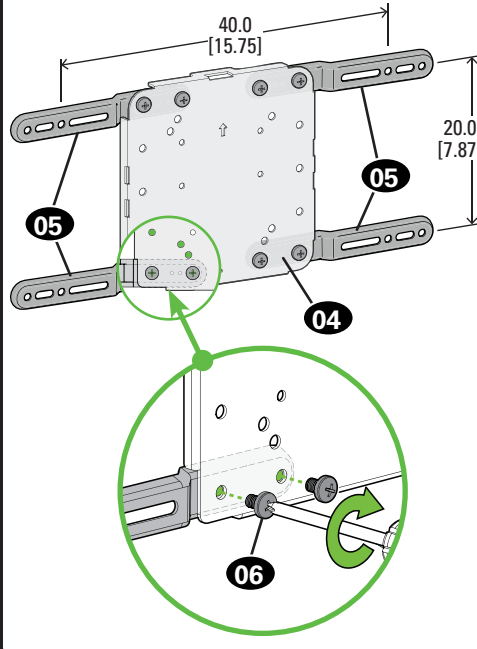

Assemble extenders **05** onto TV bracket **04** and secure using eight screws **06** in the corner holes indicated.

**E**

For TV Hole Pattern  
Measurements  
(Dimensions in cm)

**20.0 x 40.0**

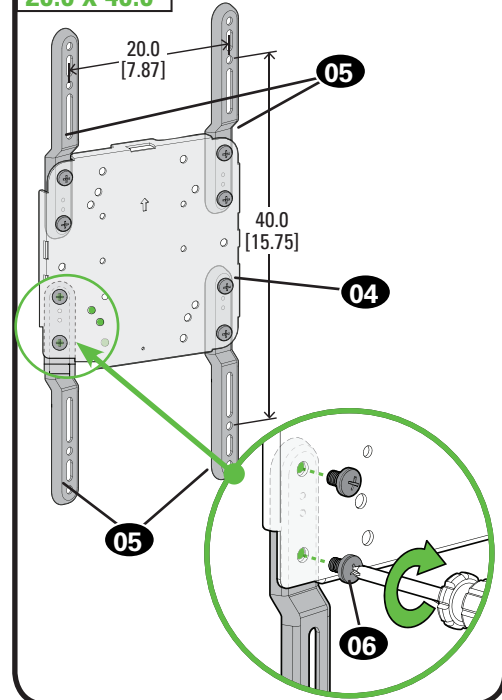

Assemble extenders **05** onto TV bracket **04** and secure using eight screws **06** in the corner holes indicated.

## 1.3 Select TV Screw Diameter

Only one size fits your TV.

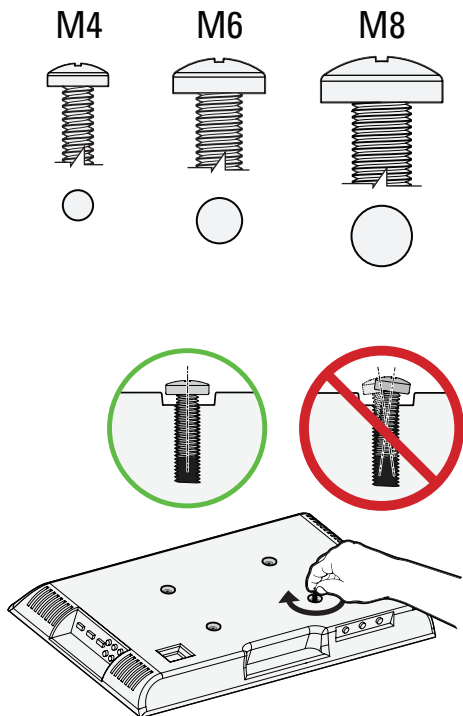

## 1.4 Select TV Screw Length

**a:** For flat-back TVs,  
no spacers **03**  
required.



FLAT BACK

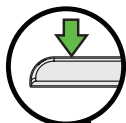

**b:** Spacers **03** supplied for:

- Round (irregular) back TVs
- Extra space needed (for cables or inset mounting holes)

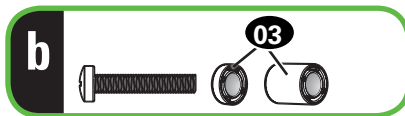

ROUND BACK

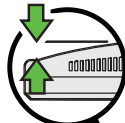

CABLES

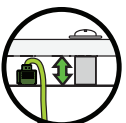

INSET HOLES

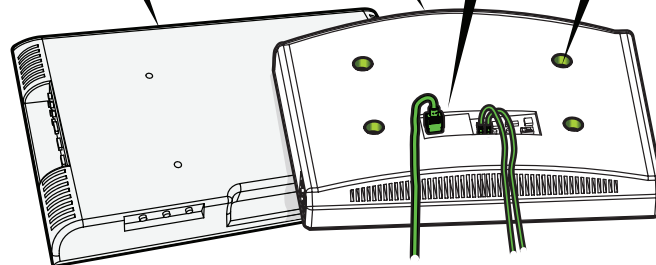
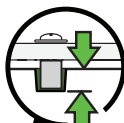

**!** If your TV included inset spacers or wall mount adapters, use them **UNDER** the mount hardware.

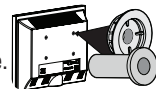

### **! CAUTION:**

Verify adequate thread engagement with your screw/washer/spacer combination **AND** TV bracket.

- Too short will not hold the TV.
- Too long will damage the TV.



Too Short

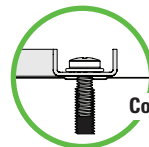

Correct

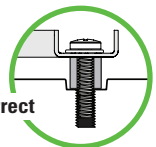

Too Long



## 1.5 Attach TV Bracket

Position your TV bracket configuration (A, B, C, D or E) onto your TV, making sure the bracket is both centered and level over your TV hole pattern.

 **NOTE:** The hanging tab **(H)** on TV bracket **04** must be oriented toward the top of the TV.

Secure the TV bracket using your selection: **(a)** screw/washer or **(b)** screw/washer/spacer.

**⚠ CAUTION:** Avoid potential personal injuries and property damage! DO NOT use power tools for this step. Tighten the screws only enough to secure the TV bracket to the TV. DO NOT overtighten the screws.

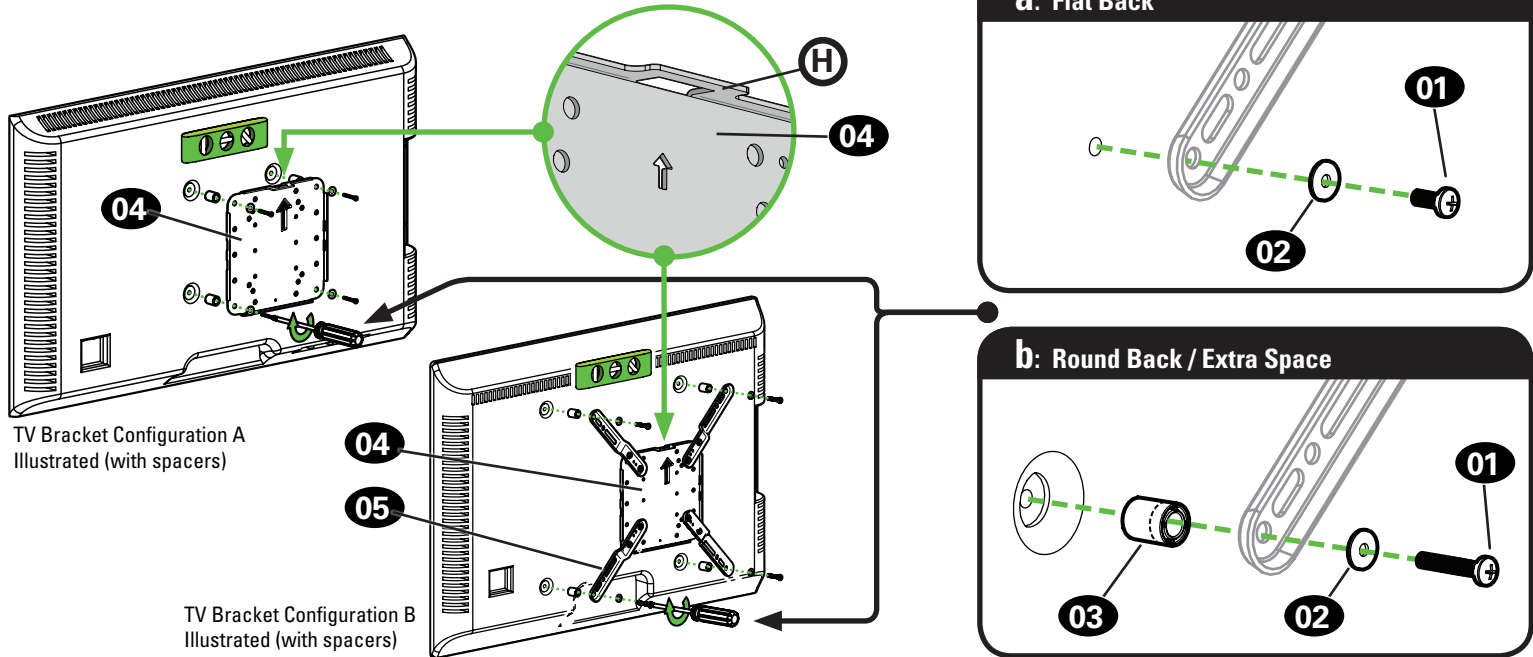

## STEP 2A Attach Wall Plate to Wall

## Wood Stud Installation

**⚠ CAUTION:** Avoid potential personal injury or property damage!

- Drywall covering the wall must not exceed 5/8 in. (16 mm)
- Minimum wood stud size: nominal 2 x 4 in. (51 x 102 mm) actual 1 ½ x 3 ½ in. (38 x 89 mm)

1. Locate your stud. Verify and mark the center of the stud by finding the stud edges using an awl, a thin nail, or an edge to edge stud finder.
2. Position the template **07** at your desired height and line up the holes with your stud center line. Level the template and tape in place.

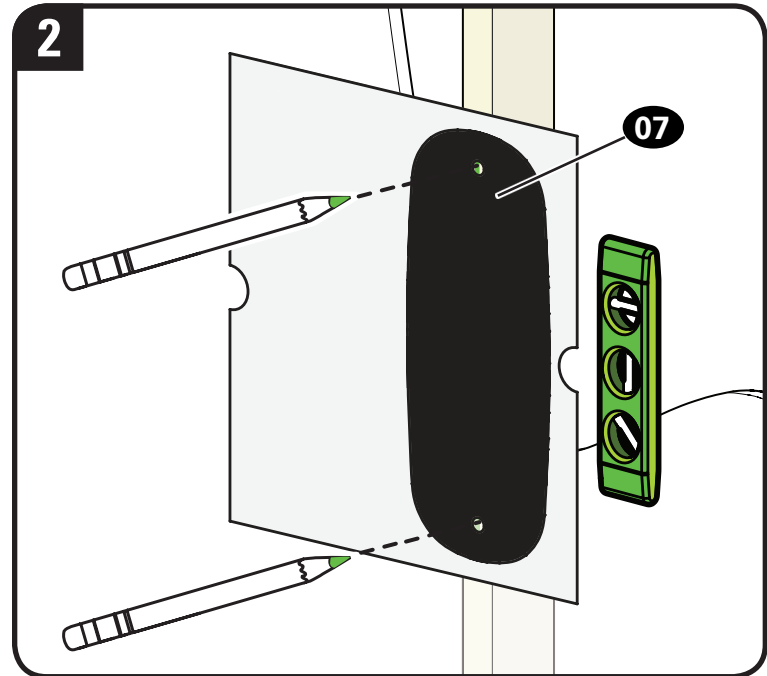
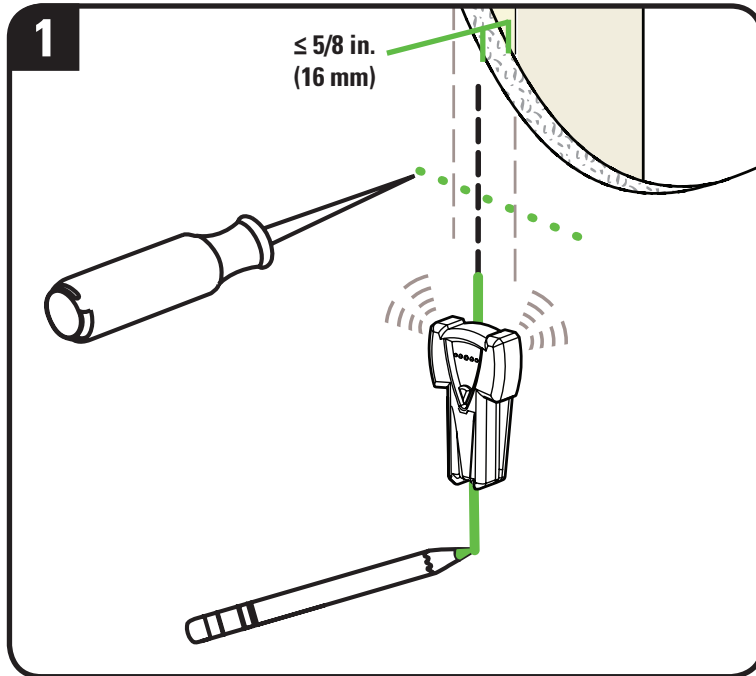

3. Drill pilot holes using a 7/32 in. (5.5 mm) diameter drill bit. Remove template **07**.

⚠ **IMPORTANT:** Be sure to drill into the center of the stud.

⚠ **IMPORTANT:** Pilot holes must be drilled to a depth of 3 in. (75 mm).

4. Install arm assembly **08** using two lag bolts **09**. Tighten the lag bolts only until they are pulled firmly against the wall plate.

⚠ **CAUTION:** Improper use could reduce the holding power of the lag bolt. **DO NOT over-tighten the lag bolts 09.**

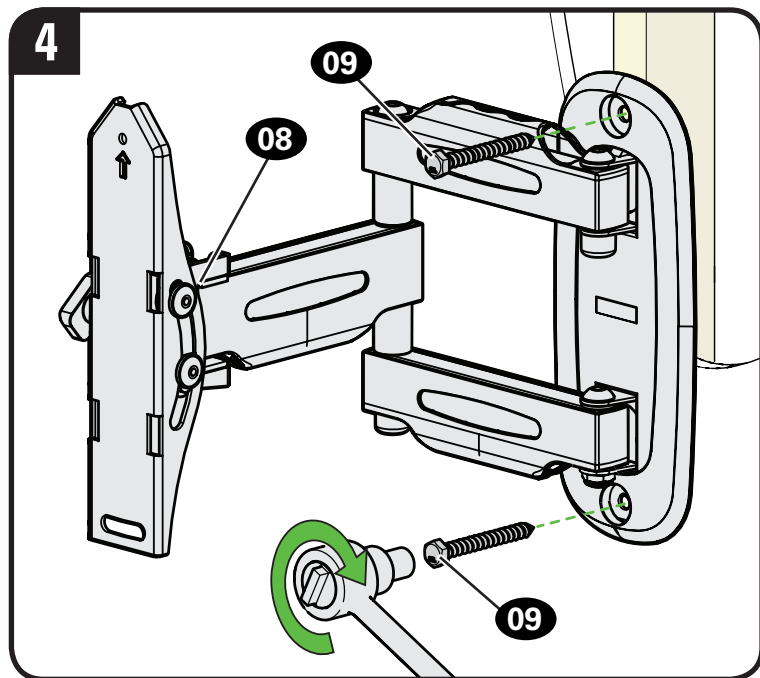
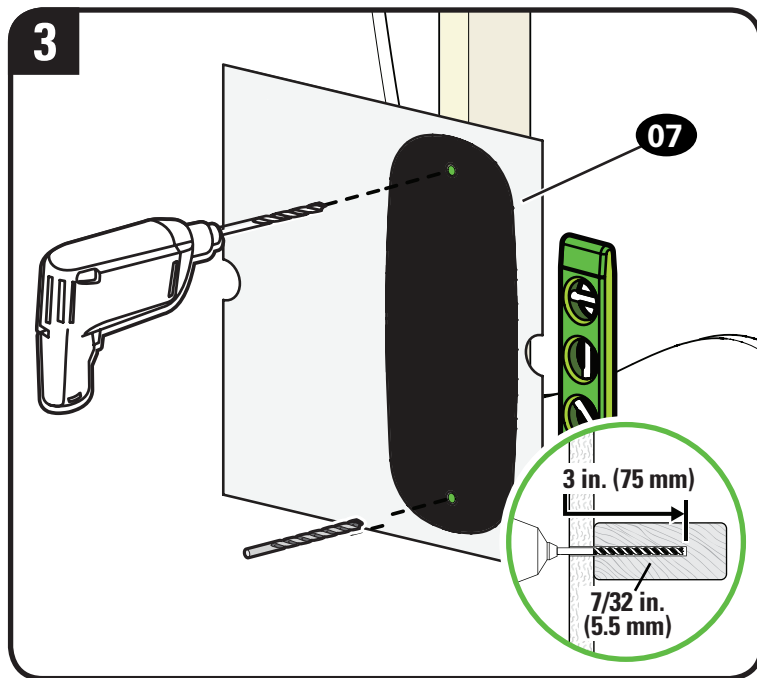

## STEP 2B Attach Wall Plate to Wall

## Solid Concrete / Concrete Block Installation

**CAUTION:** Avoid potential personal injury or property damage!

- Mount arm assembly **08** directly onto concrete surface (no wall covering)
- Minimum **solid concrete** thickness: 8 in. (203 mm)
- Minimum **concrete block** size: 8 x 8 x 16 in. (203 x 203 x 406 mm)

**Concrete Installation Kit CMK1 is not included** (see page 5) Contact Customer Service to inquire about the additional hardware.

1. Position the template **07** on the wall at your desired height. Level the template and mark the hole locations.
2. Drill two pilot holes using a 3/8 in. (10 mm) diameter masonry drill bit.

**IMPORTANT:** Pilot holes must be drilled to a depth of 3 in. (75 mm). Never drill into the mortar between blocks.

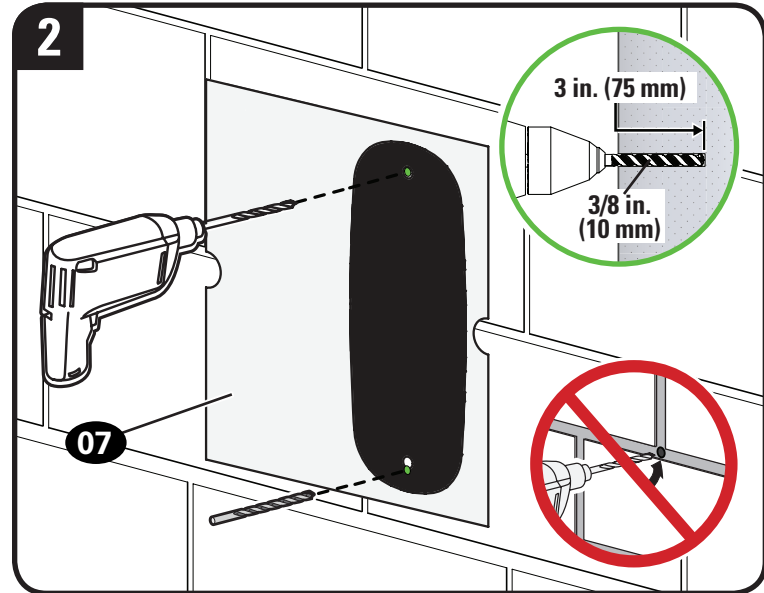
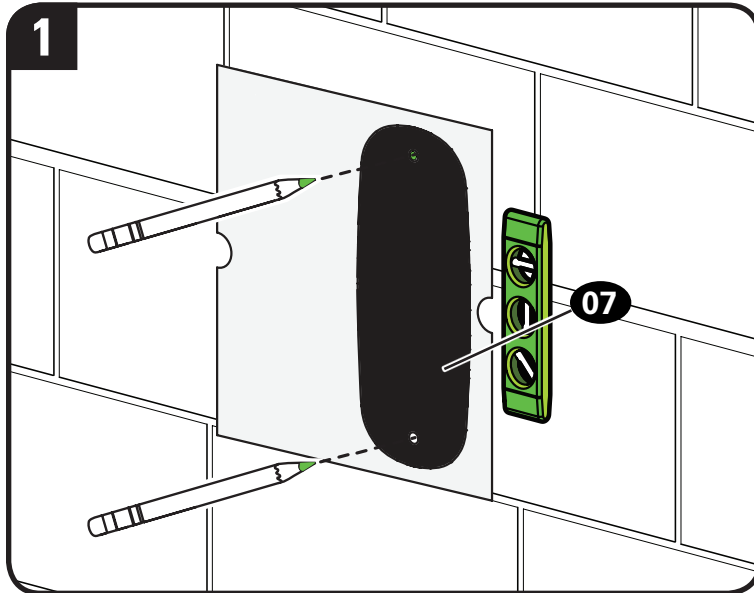

3. Remove the template **07** and insert two anchors **C1** (Fischer UX 10 x 60R - included in the Concrete Installation Kit CMK1\*).  
**⚠ CAUTION:** Be sure the anchors **C1** are seated flush with the concrete surface.
4. Install arm assembly **08** using two lag bolts **09**. Tighten the lag bolts only until they are pulled firmly against the wall plate.  
**⚠ CAUTION:** Improper use could reduce the holding power of the lag bolt. **DO NOT over-tighten the lag bolts 09.**

\*Contact Customer Service to inquire about the Concrete Installation Kit CMK1.

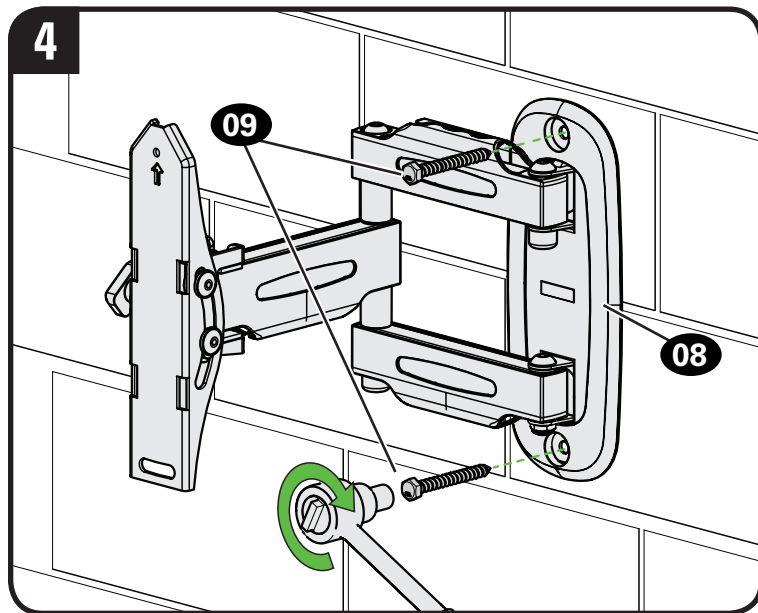
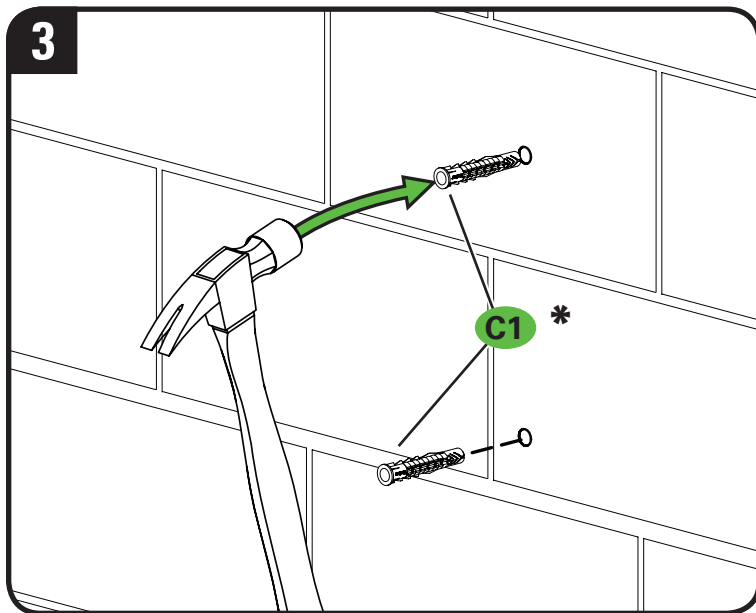

# STEP 3 Hang TV onto Wall Plate



**HEAVY!** You may need assistance with this step.

1. Install the nut cap **10** on arm assembly **08**.
2. Fold first section of the arm of arm assembly **08** against the wall to provide stability.

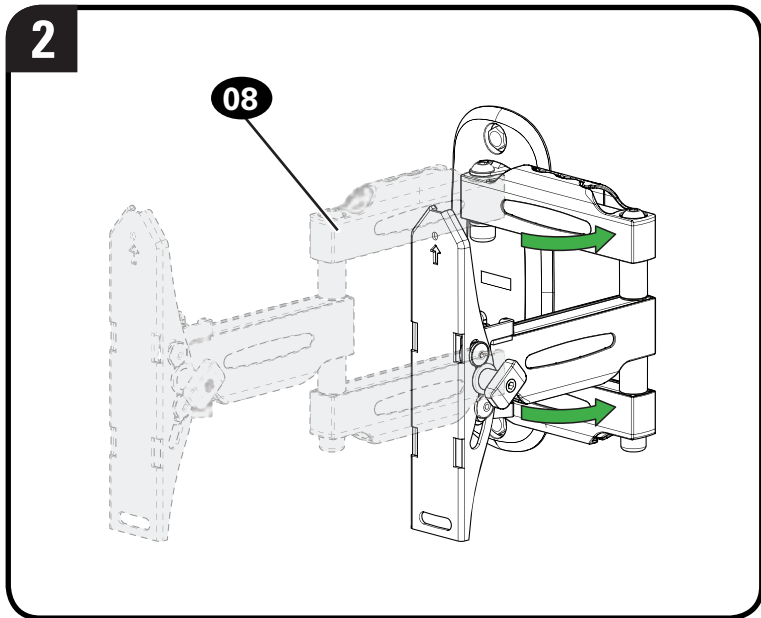
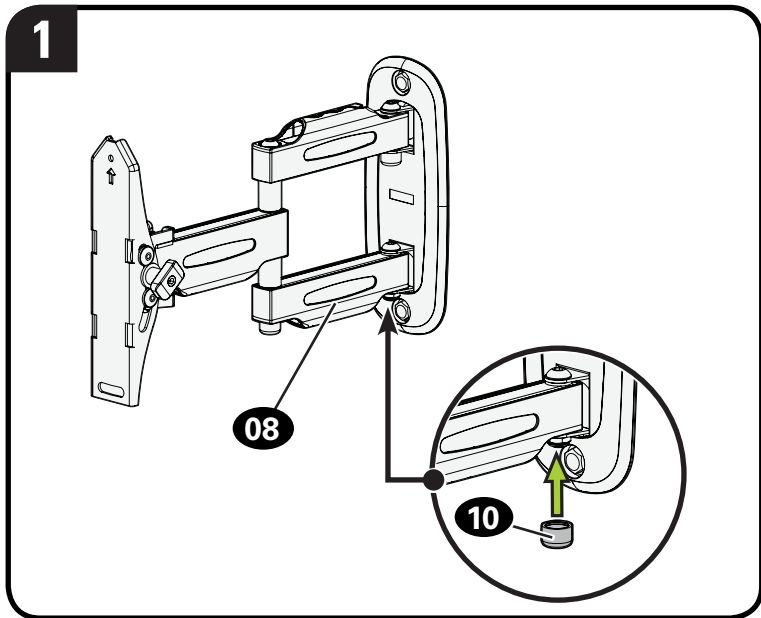

3. Hang the TV onto the arm of arm assembly **08** by first hooking the hanging tab **(H)**, then resting the TV into place.
  4. Lock the TV to the arm assembly **08** with locking screw **11** and washer **12**.
- ⚠ IMPORTANT:** This locking screw **12** must be installed to secure the TV onto the arm assembly **08**.

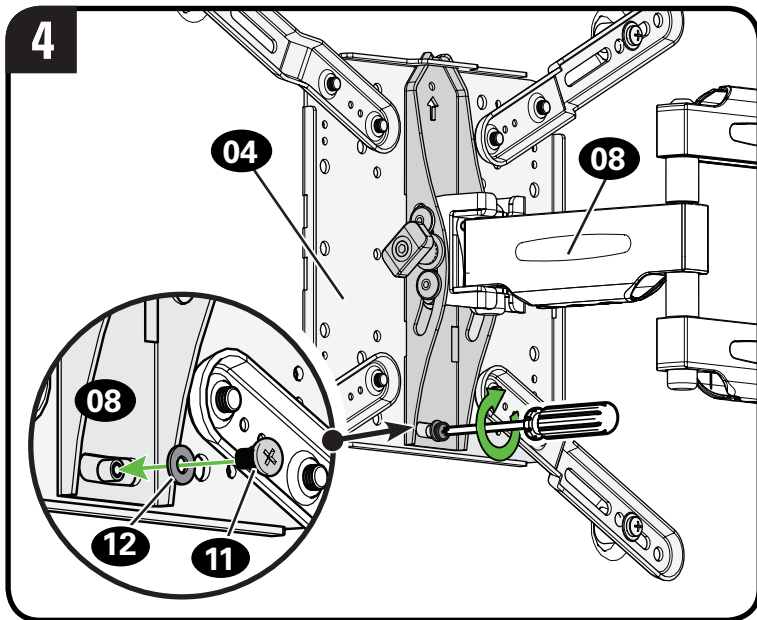
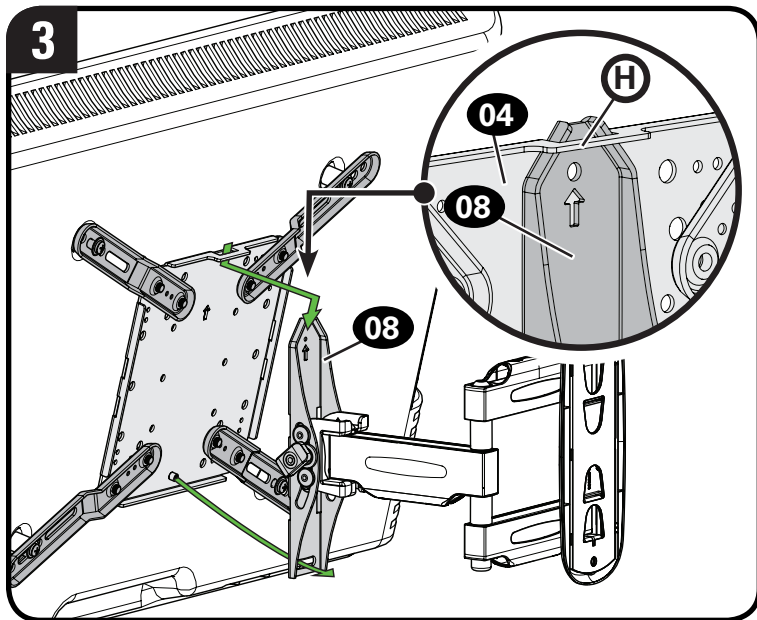

# Manage Cables

Cables can be routed through the cable channel on the top and bottom of the arm assembly **08** for a cleaner look.

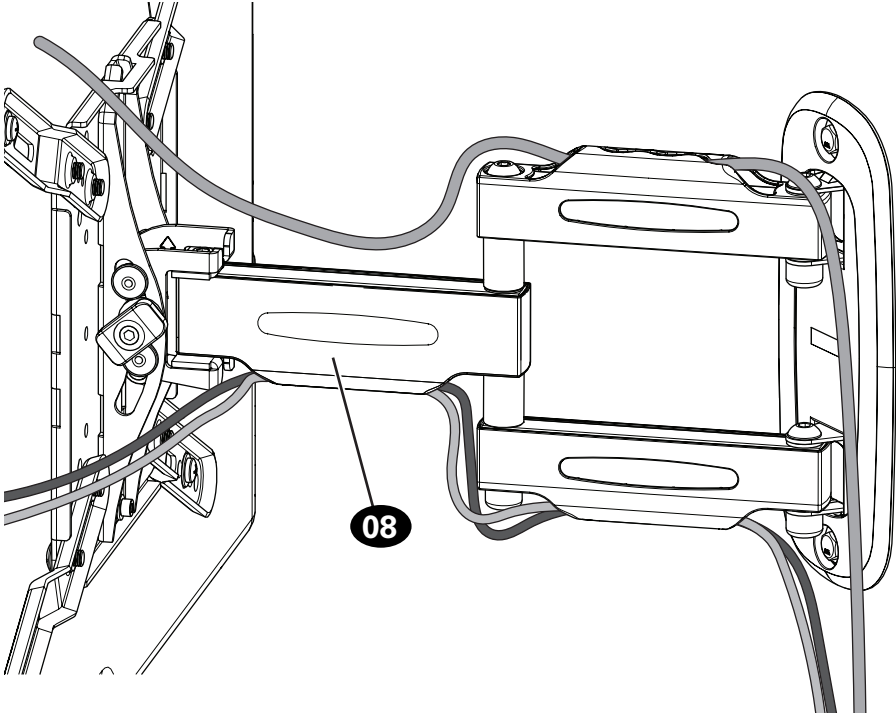



# TV Adjustments

## TILT ADJUSTMENT

Your TV should adjust easily when moved, then stay in place. If your TV is too loose or too tight, adjust the tilt tension knob by hand.

 **NOTE:** Once your TV is in place, tighten the tilt tension knob to prevent unwanted movement.

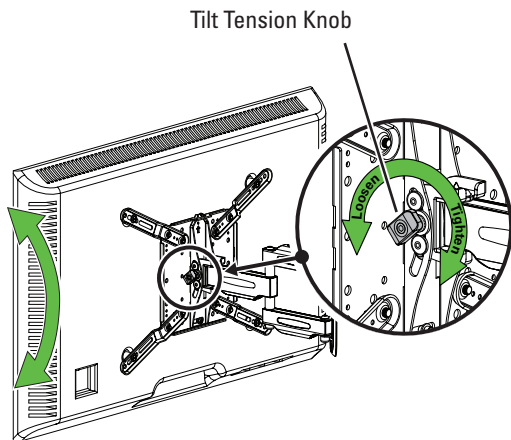

## LEVEL ADJUSTMENT

To adjust the leveling of your TV, loosen the locking screw **11**, level your TV, then tighten locking screw **11**.

 **IMPORTANT:** This locking screw **11** must be installed to secure the TV onto the arm assembly **08**.

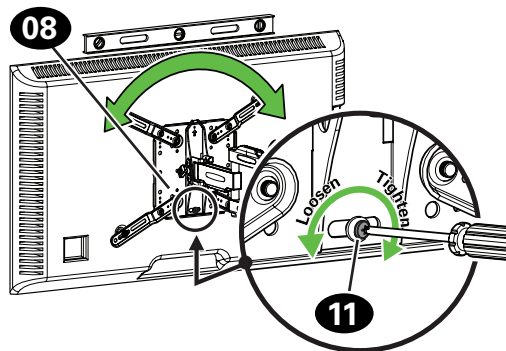

## REMOVING THE TV



**HEAVY!** You may need assistance with this step.

1. Disconnect the cables from your TV.
2. Remove locking screw **11**.
3. Carefully lift your TV up and off of wall plate assembly **08**.

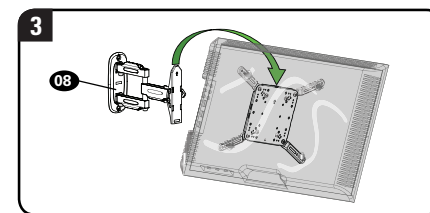
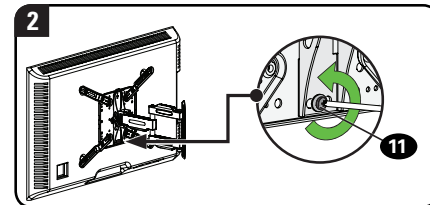
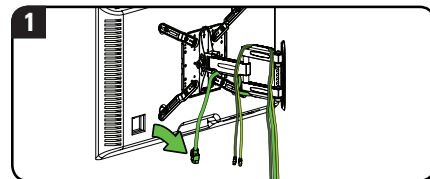

Antes de comenzar, verifiquemos que este soporte sea el ideal para sus necesidades.

**1** ¿Su televisor pesa más de 22,6 kg (50 libras), incluidos los accesorios?



No — ¡Perfecto!

Sí — Este soporte NO es compatible. Visite [Mountfinder.Sanus.com](http://Mountfinder.Sanus.com) o llame al 1-855-734-7805 para encontrar un soporte compatible.

**2** ¿De qué está hecha su pared?

**PRECAUCIÓN:**  
NO lo instale en tabiques únicamente de yeso

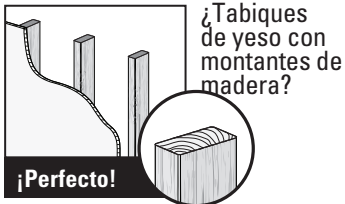

¿Hormigón sólido o bloques de cemento?

Concrete kit CMK1 (not included)

¿No está seguro?

Llame al 1-855-734-7805

**3** ¿Tiene todas las herramientas necesarias?

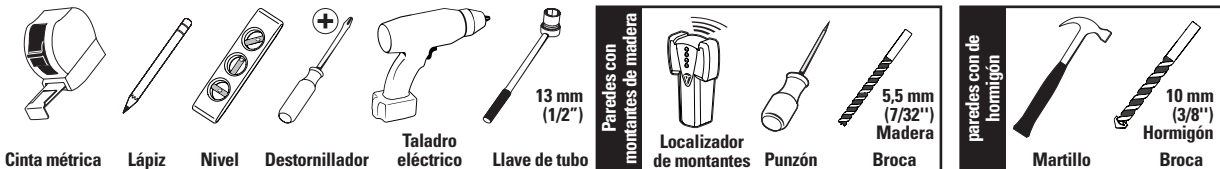

**4** ¿Listo para comenzar?

Lea estas instrucciones en su totalidad para estar seguro de sentirse cómodo con este fácil proceso de instalación. Consulte también el manual del usuario de su televisor para ver si existe algún requisito especial para instalar su televisor en la pared. Si no entiende las instrucciones o si tiene dudas acerca de la seguridad de la instalación, del ensamblado o del uso del producto, póngase en contacto con el servicio de atención al cliente al 1-855-734-7805.

**PRECAUCIÓN:** Evite posibles lesiones personales y daños materiales.

- Este producto incluye instrucciones y elementos de sujeción para su instalación en paredes con montantes de madera, en superficies de hormigón y sobre bloques de cemento. NO lo instale en tabiques únicamente de yeso.
- Este producto está diseñado para USO EN EL INTERIOR SOLAMENTE
- La pared debe soportar cinco veces el peso del televisor y del soporte juntos.
- No utilice este producto para ningún otro propósito que no sea el explícitamente especificado por el fabricante.
- El fabricante no se responsabiliza por ningún daño o lesión resultante del montaje incorrecto o de uso indebido.

## Dimensiones

Ver página 3

## Piezas y accesorios suministrados

Ver página 4

**⚠ ADVERTENCIA:** Este producto contiene piezas pequeñas que, si fuesen tragadas, podrían producir asfixia. Antes de iniciar el ensamblaje, compruebe que todas las piezas estén incluidas y en buenas condiciones. Si faltan piezas o alguna está dañada, no devuelva el artículo al distribuidor; póngase en contacto con el servicio de atención al cliente. Nunca utilice piezas deterioradas.



**NOTA:** No todos los accesorios incluidos deberán utilizarse.

## PASO 1 Fijar la placa de sujeción al televisor

Ver página 6

## 1,1 Mida el patrón de orificios del televisor

Mida en mm el ancho y el alto del patrón de orificios del televisor.

Anote las medidas: **Ancho** \_\_\_\_\_ **cm** x **Alto** \_\_\_\_\_ **cm**

## 1,2 Arme la placa de sujeción del televisor

Determine qué configuración de placa de sujeción debe usar (A, B, C, D o E) según las medidas del patrón de orificios del televisor (**W cm x H cm**).

**A** Los patrones de orificios más pequeños solo requieren placa de sujeción **04**. No utilice las cuatro extensiones de la placa de sujeción **05** ni los ocho tornillos **06**.

**B-E** Ensamble las extensiones **05** de la placa de sujeción y la placa de sujeción **04** tal como se muestra en la ilustración. Fije colocando ocho tornillos **06** en los orificios de las esquinas que se muestran en la imagen.

## 1.3 Seleccione el diámetro de los tornillos para el televisor

Enrosque manualmente los tornillos en los encastres roscados del dorso del televisor a fin de determinar qué diámetro de tornillos (M4, M6 o M8) utilizar.

## 1.4 Seleccione el largo de los tornillos para el televisor

**a:** Si el dorso del televisor es plano, no se requieren espaciadores **03**.

**b:** Los espaciadores **03** y los tornillos largos se proporcionan para:

- televisores con dorso irregular o redondeado
- dejar un espacio adicional para cables o orificios de montaje intercalados

**▲ PRECAUCIÓN:** Verifique que el tornillo o la combinación de tornillo y espaciador enrosquen correctamente.

— Si el tornillo es demasiado corto, no sostendrá el televisor. — Si es demasiado largo, dañará el televisor.

 Si su televisor incluye espaciadores empotrados o adaptadores para soportes de pared, úselos **BAJO** el hardware de montaje.

## 1.5 Fije la placa de sujeción

Coloque su configuración de soporte de televisor (A, B, C, D o E) sobre el patrón de orificios de su televisor, asegurándose de que el soporte esté centrado sobre el patrón de orificios del televisor y nivelado.

 **NOTA:** La lengüeta colgante **(H)** del soporte del televisor **04** debe estar orientada hacia la parte superior del televisor.

Fije el soporte con su selección de tornillo/arandela **(a)** parte trasera plana o espaciador/tornillo/arandela **(b)** parte trasera redondeada / espacio adicional.

**▲ PRECAUCIÓN:** Evite posibles lesiones personales y daños materiales. **NO** use herramientas eléctricas para este paso. Apriete los tornillos con la fuerza adecuada para fijar la placa de sujeción al televisor. **NO** los apriete demasiado.

## PASO 2A Fijar la placa mural

## Montantes de madera

Ver página 10

**▲ PRECAUCIÓN:** Evite lesiones y daños materiales.

- El yeso que recubre la pared no debe exceder los 16 mm (5/8")
- Tamaño mínimo del montante de madera: nominal 51 mm x 102 mm (2" x 4"); real 38 mm x 89 mm (1½" x 3½")

1. Localice un montante. Busque los bordes del montante y marque el centro con un punzón o un clavo delgado, o bien utilice un detector de bordes de montantes.
2. Ubique la plantilla de placa mural **07** a la altura deseada y alinee los orificios con la línea central de los montantes. Nivele la plantilla y fíjela con cinta adhesiva en el lugar.

- Con una mecha de 5.5 mm (7/32") de diámetro, realice los orificios guía. Retire la plantilla de placa mural **07**.
  - ⚠ IMPORTANTE:** Asegúrese de perforar el centro del montante.
  - ⚠ IMPORTANTE:** Los orificios guía deben realizarse hasta una profundidad de 75 mm (3").
- Instale el módulo de la placa mural **08** usando dos tornillos tirafondo **09**. Ajuste los tornillos tirafondo solamente hasta que queden firmes contra la placa mural.
  - ⚠ PRECAUCIÓN:** El uso indebido podría reducir la capacidad de retención de los tornillos. **NO ajuste en exceso los tornillos tirafondo.**

## PASO 2B Fijar la placa mural Hormigón sólido o bloques de cemento

Ver página 12

### **⚠ PRECAUCIÓN:** Evite lesiones y daños materiales.

- Instale el módulo de la placa mural **08** directamente sobre la superficie de hormigón
- Espesor mínimo del hormigón: 8 pulgadas (203 mm)
- Tamaño mínimo del bloque de cemento: 8 x 8 x 16 pulgadas (203 x 203 x 406 mm)

### **El Kit de instalación en hormigón**

**CMK1 no está incluido** (Ver página 5) Comuníquese con el servicio de atención al cliente al 1-855-734-7805 para solicitar que le enviemos los elementos de sujeción adicionales.

- Coloque la plantilla de la placa mural **07** en la pared a la altura que desee. Nivele la plantilla de la placa mural y marque la ubicación de los orificios.
- Realice los orificios guía con una mecha para mampostería de 3/8" (10 mm) de diámetro.
  - ⚠ IMPORTANTE:** Los orificios guía deben realizarse hasta una profundidad de 3" (75 mm). Nunca perfora el cemento que une los bloques.
- Retire la plantilla de la placa mural **07** e introduzca dos anclajes **C1** (Fischer UX 10 x 60R - incluidos en el Kit de instalación en hormigón CMK1\*).
- ⚠ PRECAUCIÓN:** Cerciórese de que los anclajes **C1** queden nivelados respecto de la superficie de hormigón.
- Instale el módulo de la placa mural **08** usando dos tornillos tirafondo **09**. Ajuste los tornillos tirafondo solamente hasta que queden firmes contra la placa mural.
  - ⚠ PRECAUCIÓN:** El uso indebido podría reducir la capacidad de retención de los tornillos. **NO ajuste en exceso los tornillos tirafondo **09**.**

\* Comuníquese con el servicio de atención al cliente al 1-855-734-7805 para solicitar que le enviemos el Kit de instalación en hormigón.

## PASO 3 Colgar el televisor en la placa mural

Ver página 14



**¡ELEMENTO PESADO!** Es posible que necesite ayuda en este paso.

1. Instale la tapa **10** en del módulo de la placa mural **08**.
2. Pliegue la primera sección del brazo del módulo de la placa mural **08** contra la pared para dar mayor estabilidad.
3. Para colgar el televisor en el brazo del módulo de la placa mural **08**, primero enganche la lengüeta colgante **H** y luego apoye el televisor en su lugar.
4. Fije el televisor al módulo de la placa mural **08** con el tornillo de seguridad **11** y la arandela **12**.

**! IMPORTANTE:** Este tornillo de seguridad **11** debe instalarse para fijar el televisor al módulo de la placa mural **08**.

## Organización de cables

Ver página 16

Los cables pueden pasarse por los canales para cables que se encuentran en la parte superior del brazo del módulo de la placa mural **08** para un aspecto más prolijo.

Pase los cables alrededor del poste del brazo y a través del área abierta del brazo, tal como se muestra en la imagen, para evitar aplastar los cables al plegar el brazo.

# Ajustes del televisor

Ver página 17

## AJUSTE DE LA INCLINACIÓN

El televisor debe acomodarse fácilmente al moverlo, y luego quedar en su lugar.

Si el televisor está demasiado suelto o demasiado ajustado, ajuste la perilla de tensión de inclinación manualmente.



**NOTA:** Una vez que el televisor esté en su lugar, ajuste la perilla de tensión de inclinación para evitar movimientos indeseados.

## AJUSTE DEL NIVEL

Para ajustar la nivelación de su televisor, afloje el tornillo de seguridad **11**, nivele el televisor, y luego ajuste el tornillo de seguridad **11**.

**⚠ IMPORTANTE:** Este tornillo de seguridad **11** debe instalarse para fijar el televisor al ensamblaje de la placa mural **08**.

## EXTRACCIÓN DEL TELEVISOR



**¡ELEMENTO PESADO!**  
Es posible que necesite ayuda en este paso.

1. Desconecte todos los cables del televisor.
2. Retire el tornillo **11**.
3. Levante el televisor y retírelo del módulo de la placa mural **08**.

# SANUS

**Watch the installation video or call our Customer Care team for help**



**SAN.US/2848**



**1-855-734-7805**

Legrand AV Inc. and its affiliated corporations and subsidiaries (collectively, "Legrand"), intend to make this manual accurate and complete. However, Legrand makes no claim that the information contained herein covers all details, conditions, or variations. Nor does it provide for every possible contingency in connection with the installation or use of this product. The information contained in this document is subject to change without notice or obligation of any kind. Legrand makes no representation of warranty, expressed or implied, regarding the information contained herein. Legrand assumes no responsibility for accuracy, completeness or sufficiency of the information contained in this document.

©2019 Legrand AV Inc. All rights reserved. Sanus is a division of Legrand. SANUS and the SANUS logo are registered trademarks.

Legrand AV Inc. • 6436 City West Parkway • Eden Prairie, MN 55344 USA

6901-602395 00