

# SANUS SYSTEMS

THE UNION OF FORM AND FUNCTION

## Assembly Instructions for Model: VMPO

Thank You for your purchase of a Sanus Systems Vision Mount! The VMPO is designed to securely attach a Flat Panel LCD to a cabinet or an armoire. It will allow the ability to pull the TV out and swivel. It can also be used with a VM200 for tilting LCDs or a VMPL50 for Plasmas.

**Safety Warning:** If you do not understand these directions, or have any doubts about the safety of the installation, please call a qualified contractor or contact Sanus at 800.359.5520 or [www.sanus.com](http://www.sanus.com). Check carefully to make sure that there are no missing or defective parts. Our customer service representatives can quickly assist you with installation questions and missing or damaged parts. Replacement parts for products purchased through authorized dealers will be shipped directly to you. Never use defective parts. Improper installation may cause damage or serious injury. Do not use this product for any purpose that is not explicitly specified by Sanus Systems. Sanus Systems can not be liable for damage or injury caused by incorrect mounting, incorrect assembly, or incorrect use. Please call Sanus Systems before returning products to the point of purchase.

**Required Tools:** Drill, 1/4" Drill Bit, wrench or socket set, phillips screw driver

**Check carefully to ensure that no hardware or parts are missing**

**Note:** Hardware shown at actual size \*Some items not shown at same scale

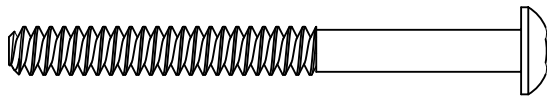

(6) Button Head Bolt - a

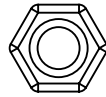

(6) 1/4 20 Nut - b

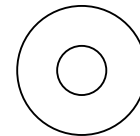

(6) Washer - c



(4) M8 Nut - d

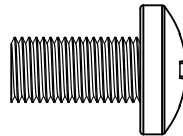

(4) M8 x 16 Bolt - e

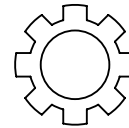

(4) M8 Lock Washer - f

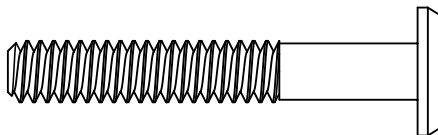

(4) Furniture Bolt - g

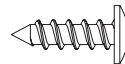

(4) Wood Screw - h

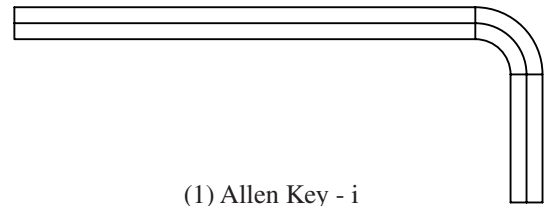

(1) Allen Key - i

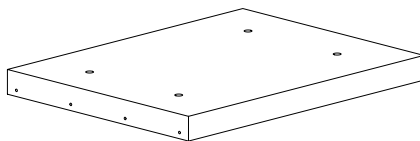

(1) Base - j

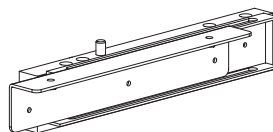

(1) Left Glide - k

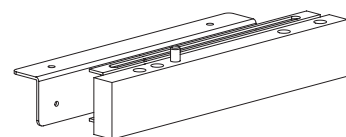

(1) Right Glide - l

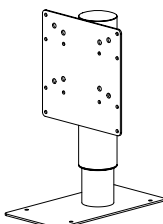

(1) Top Assembly - m\*



(1) Handle - n

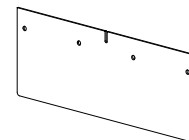

(1) Front Cover - o

## TV Attachment Hardware:

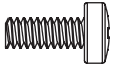

(4) M4 x 10 Bolt - p

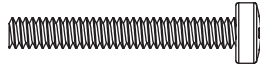

(4) M4 x 30 Bolt - q

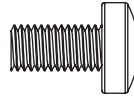

(4) M6 x 12 Bolt - r

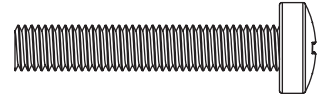

(4) M6 x 35 Bolt - s



(4) M4 Lock Washer - t



(4) M6 Lock Washer - u

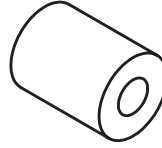

(4) M4 Spacer - v

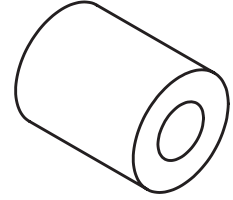

(4) M6 Spacer - w

---

## Step 1: Prepare Holes in Mounting Surface

### Section A: Mounting the VMPO to the Sanus CFAR47cb

On the bottom side of the Mid Shelf on the CFAR47cb you should see 6 starter holes that have been pre-drilled in a pattern that is shown in Diagram 1. With a Drill and a 1/4" Drill Bit, proceed to drill out all 6 holes so they go all the way through the shelf.

### Mounting the VMPO to any other surface

Tape the Paper Template provided to the desired shelf the VMPO is to be mounted on. Using a Drill and a 1/4" Drill Bit, drill a hole in each marked location (6 total) in the Shelf. You should have 6 drilled holes that match the pattern shown in Diagram 1.

**Note: Diagram 1 is a Cutaway View**

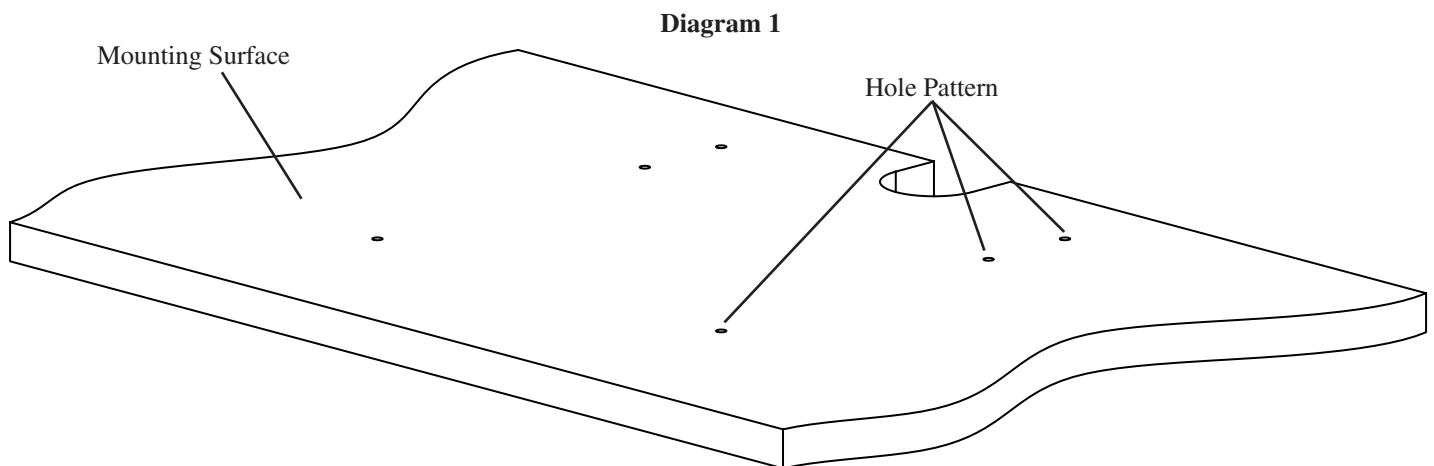

**WARNING: It is the responsibility of the installer to verify the surface the VMPO is mounted to is secured so that it will NOT tip forward when the television is pulled out into its extended position. The mounting surface must be capable of supporting 5 times the total weight of the television and the mount.**

### Step 2: Attach Glides to Mounting Surface

To mount the Glides (k,l), insert a Button Head Bolt (a) through each indicated hole in the wood portion of the Glide, the Shelf you are mounting the VMPO to, a Washer (c), and finally thread a 1/4 20 Nut (b) onto the end. See the Detailed View of Diagram 2 for assistance. Tighten the Nut with a wrench until tight. Repeat the process until all 3 Button Head Bolts are fastened securely on each Glide.

**Note: Make sure the end of the Glide with a Dowel is facing the front of the Shelf.**

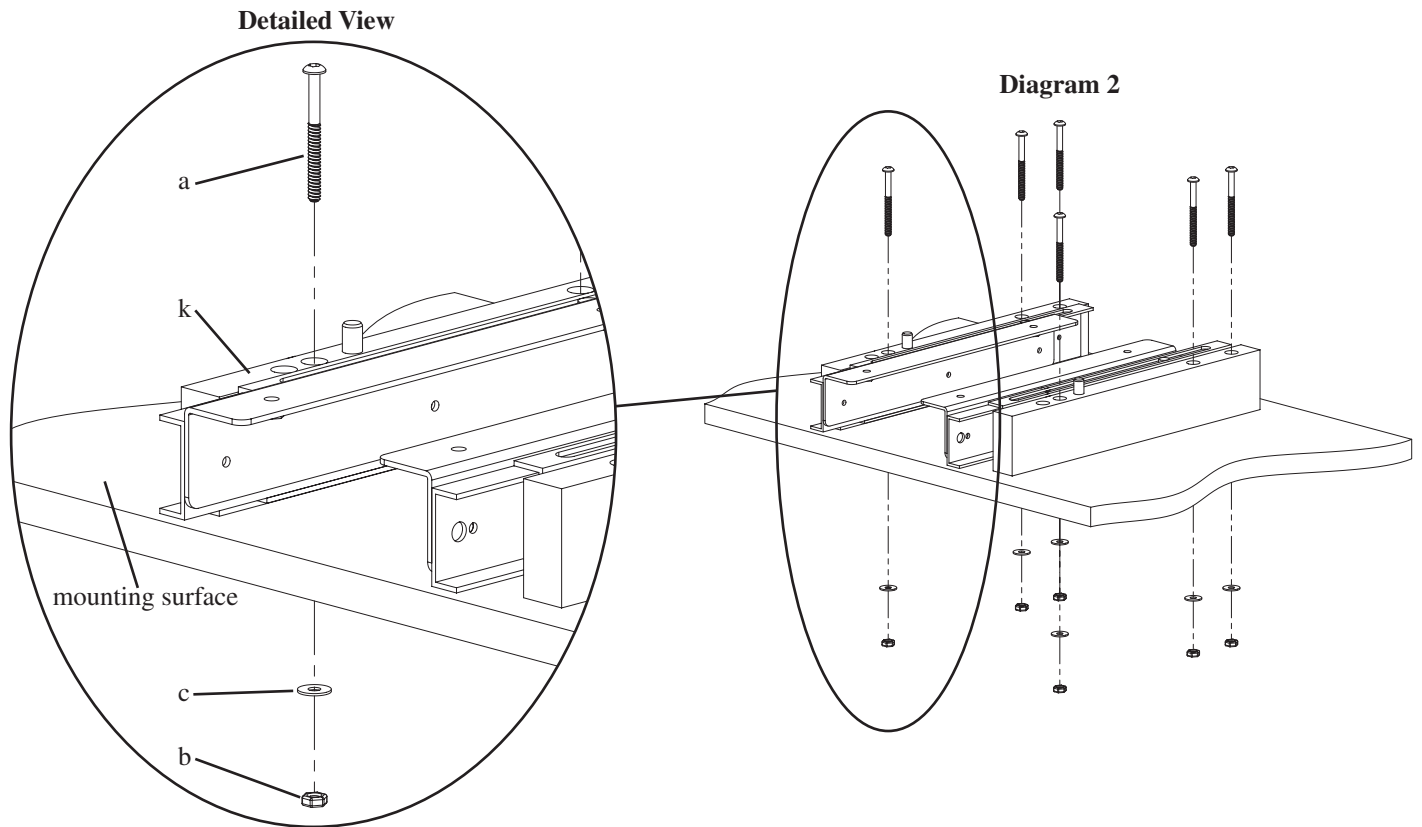

### Step 3: Reposition the Dowels (optional)

To have the VMPO extend further, simply remove the Dowels by lifting them out of the Glides (k,l) and placing them in the front hole location as shown in Diagram 3.

**WARNING: Proceed with this step at your own risk!**

**Note: Sanus Always recommends fastening the cabinet or armoire to the wall! If you choose to remove this Dowel, it is the responsibility of the installer to verify the mounting surface is capable of supporting the weight of the television in the fully extended position.**

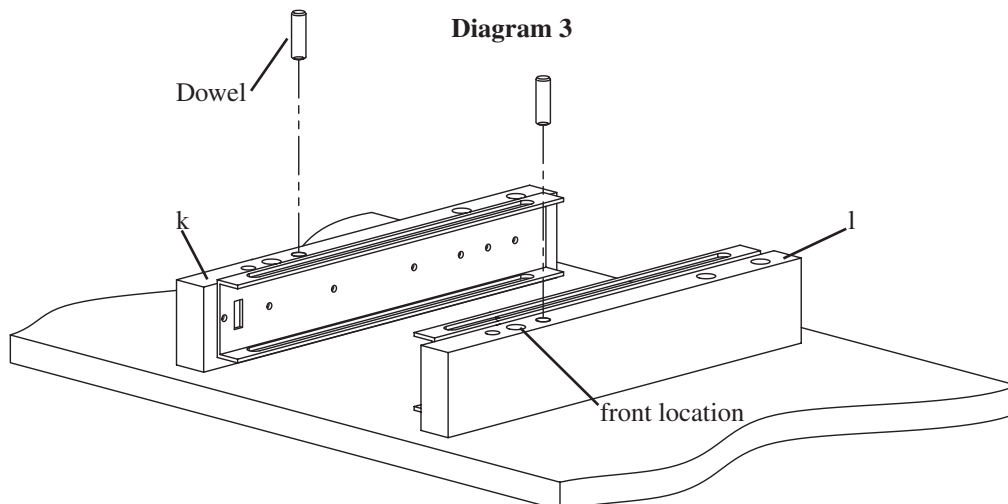

#### Step 4: Attach Top Assembly to Glides

Orient the Base (j) so that the 4 small holes face the front and the side with the long grooves faces down. Then orient the Top Assembly (m) so that the vertical tube is closer to the back. Insert a Furniture Bolt (g) through the Top Assembly, the Base, and finally thread it into the Glide (k,l). See the Detailed View of Diagram 4 for assistance. Repeat process for each of the remaining 3 Furniture Bolts. Proceed to tighten each Furniture Bolt firmly with the Allen Key (i).

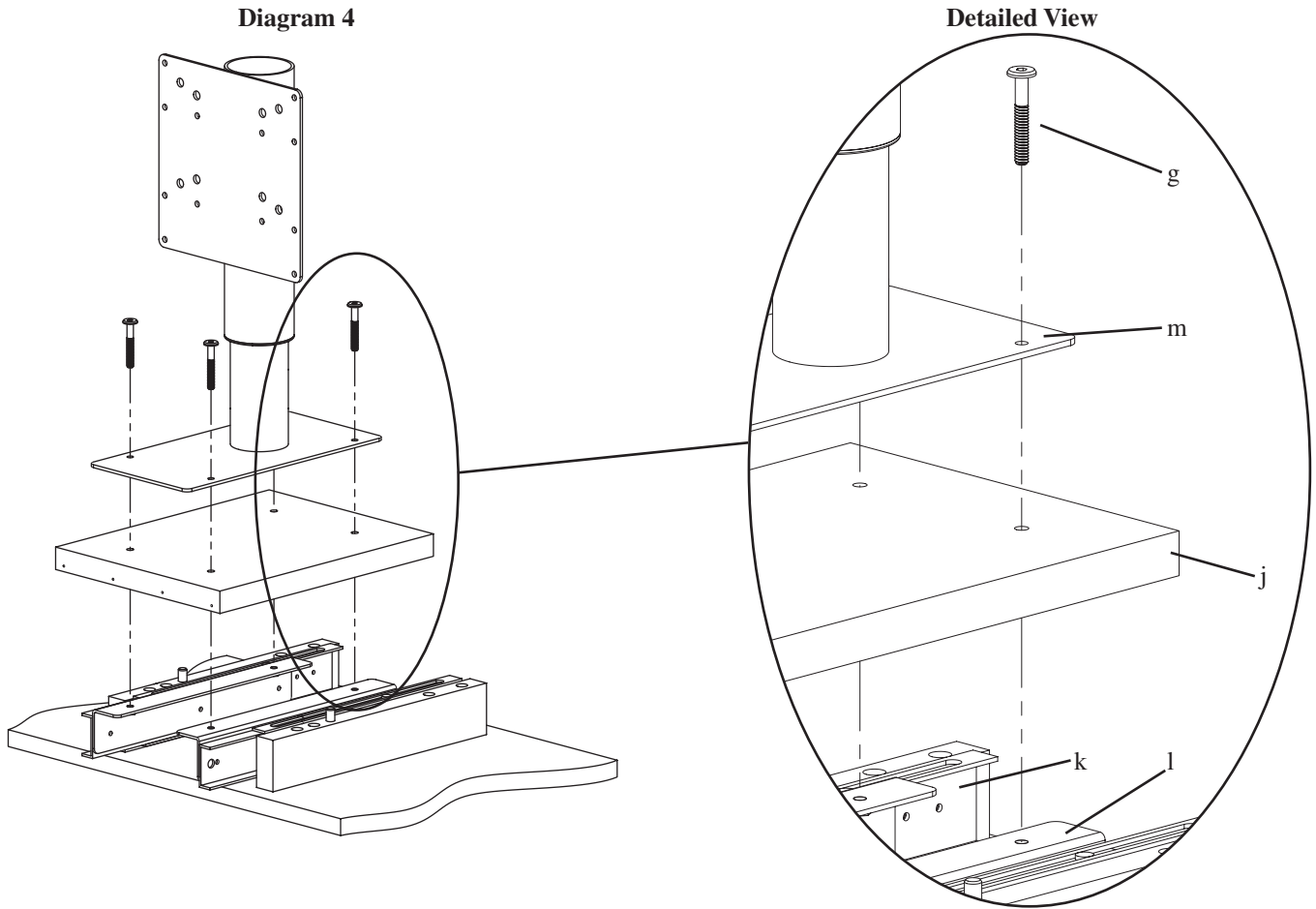

#### Step 5: Attach Handle and Front Cover

Simply insert a Wood Screw (h) through the appropriate hole in the Front Cover (o), the U shaped slit in the Handle (n) and thread it into the appropriate hole in the front of the Base (j) as shown in the Detailed View of Diagram 5. Repeat process until all 4 Wood Screws are fastened to the Base. Tighten each Wood screw with a phillips screw driver.

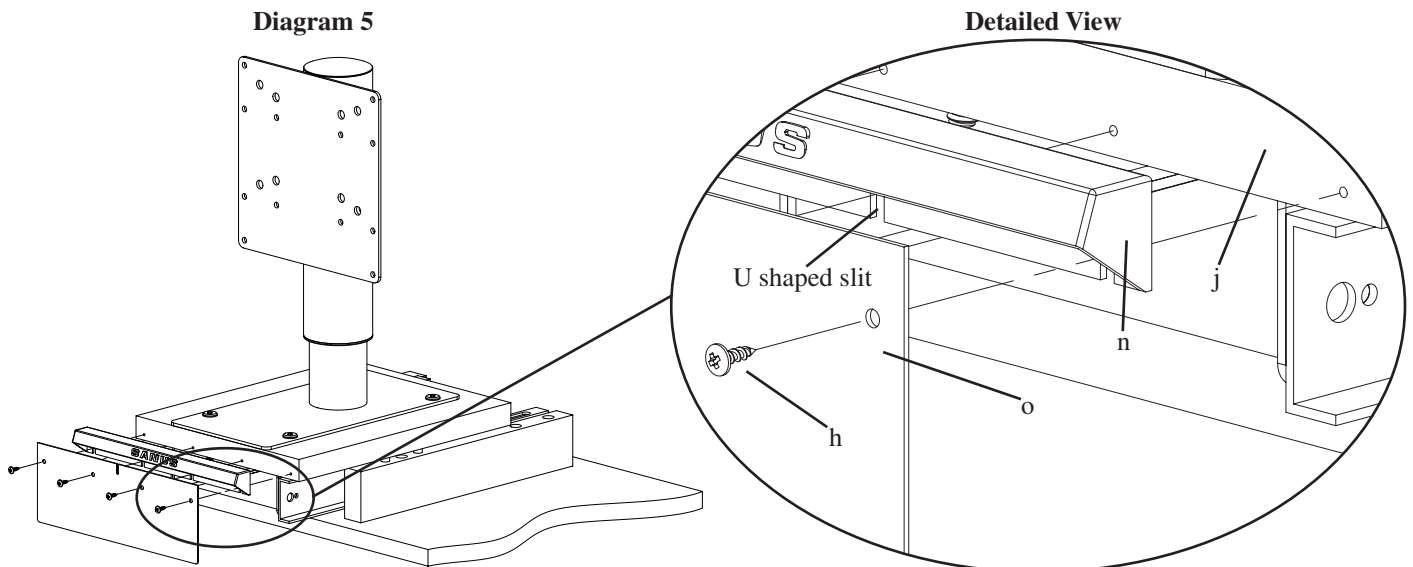

### Step 6: Adjust the height of the Top Assembly

Using the Allen Key (i), loosen the pin that is shown in the Detailed View of Diagram 6. Once the Pin and the Nut are removed, raise or lower the free moving part of the Top Assembly (m) to the desired height and reinsert the Pin and the Nut into the appropriate hole. Tighten with the Allen Key.

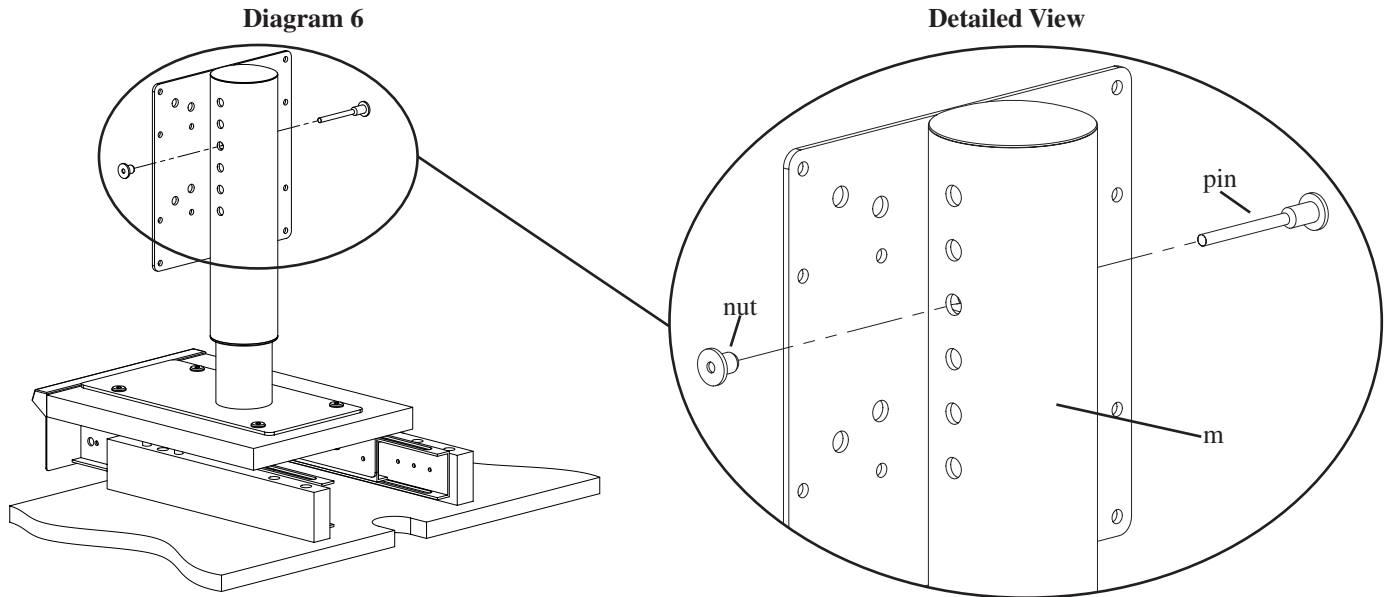

### Step 7: Attach Flat Panel LCD directly to VMPO

To figure out the hardware needed to attach the VMPO directly to the TV, start by determining the diameter of the Bolt (M4 or M6) your TV requires by hand threading them into the threaded insert on the back of the TV. If you encounter any resistance stop immediately! Once you have determined the correct diameter, see the appropriate Diagram below. You will thread the Bolt through the appropriate Lock Washer (t,u), the Top Assembly (m), and finally thread it into the TV. Proceed to tighten all 4 Bolts until tight with a phillips screw driver.

**Note: Instances where there is an obstruction near the threaded insert in the back of the TV will require the use of a Spacer (v,w) and the longer Bolt (q,s). For those instances see the M4 x 30 or M6 x 35 Diagram.**

**M4 x 10 Diagram**

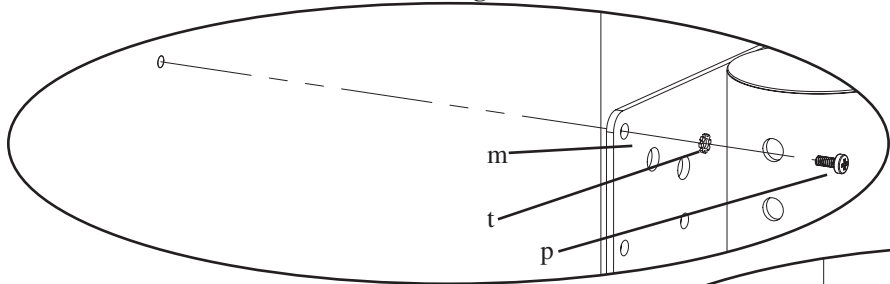

**M4 x 30 Diagram**

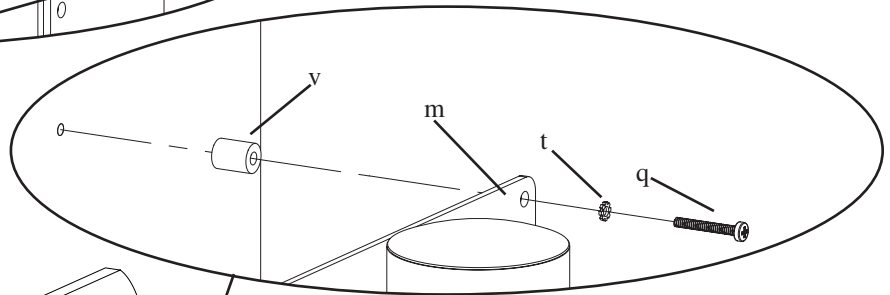

**M6 x 12 Diagram**

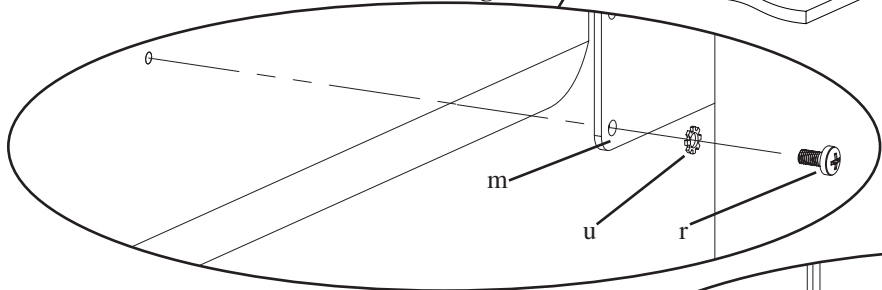

**M6 x 35 Diagram**

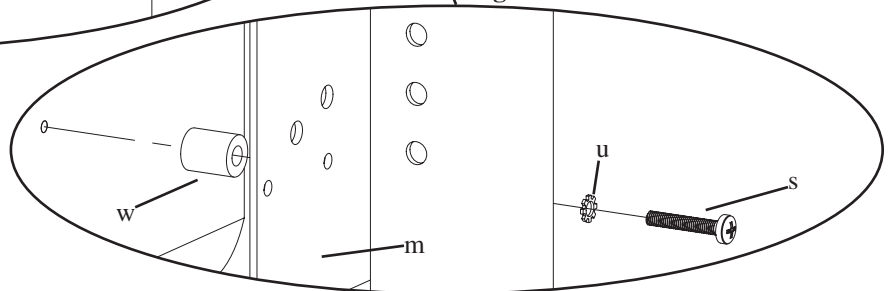

If using a VM200 for tilt compatibility with flat panel LCD sets follow Step 8.

**Step 8: Attach the VM200 Wall Plate to Top Assembly**

Insert a M8 Bolt (e) through the appropriate hole in the VM200 Wall Plate, the Top Assembly (m), the M8 Lock Washer (f), and thread into a M8 Nut (d). See Diagram 8 for Assistance. Repeat the process for each remaining M8 Bolt. Proceed to tighten each M8 Nut with a wrench.

**Note: Proceed to follow the instruction manual that came with the VM200 Wall Mount to attach the Television to the wall plate.**

**Diagram 8**

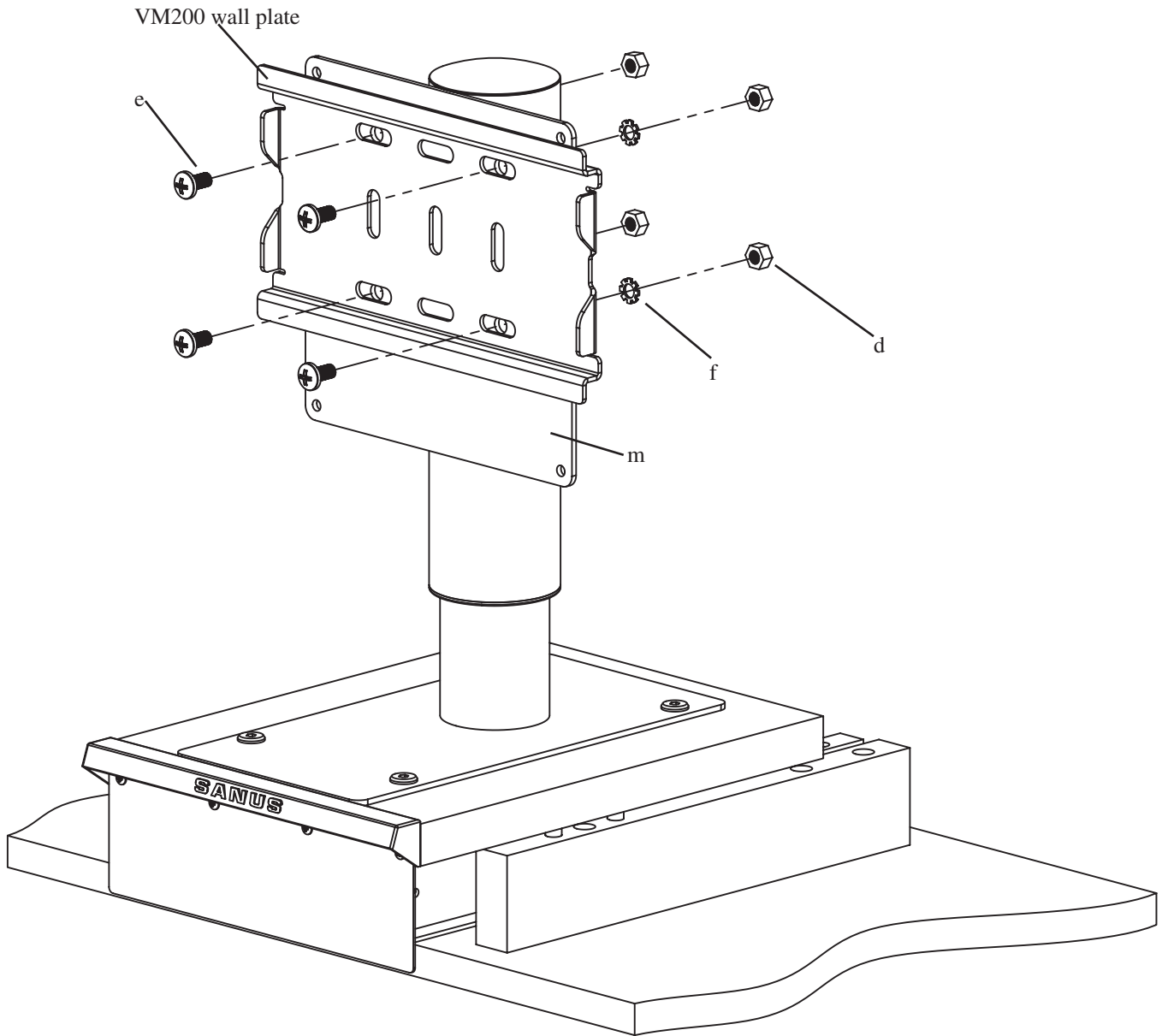

If using a VMPL50 for tilt compatibility with a plasma set follow Step 9.

**Step 9: Attach the VMPL50 Wall Plate to Top Assembly**

Insert a M8 Bolt (c) through the appropriate hole in the VMPL50 Wall Plate, the Top Assembly (m), the M8 Lock Washer (f), and thread it into a M8 Nut (d). See Diagram 9 for Assistance. Repeat the process for each remaining M8 Bolt. Proceed to tighten each M8 Nut with a wrench.

**Note: Proceed to follow the instruction manual that came with the VMPL50 Wall Mount to attach the Television to the wall plate.**

Diagram 9

